

PAPER • OPEN ACCESS

Research on the relation between the percentage of elastomeric threads in the yarn and the stretch of punto di roma jersey

To cite this article: Tania P Peneva *et al* 2021 *IOP Conf. Ser.: Mater. Sci. Eng.* **1031** 012033

View the [article online](#) for updates and enhancements.

Research on the relation between the percentage of elastomeric threads in the yarn and the stretch of punto di roma jersey

Tania P Peneva, Diana R Balabanova, Galia G Dolapchieva and Krasimir Krastev

Takia University of Stara Zagora, Faculty of Technics and Technologies of Yambol,
38 “Graff Ignatiev” Str., 8602 Yambol, Bulgaria

e-mail: tanna58971701@abv.bg

Abstract. The last few years have shown a tendency for an increase in the production of knitting fabrics made of yarns containing elastomeric threads. A main point of the construction of such garments is the determination of their deformation properties, which change depending on the type of the knit and the composition of the yarn. Determining these properties requires textile testing which takes time and requires additional expenditures which necessitates the development of new methods for their evaluation. The aim of this work is to examine the relation between the distortion features of elastic knit fabrics and the percentage of elastomeric threads in the yarn. The subject of the study is a group of knit fabrics with the Punto di Roma stitch structure containing elastomeric threads from 2% to 6%. Based on the proven statistical significance of the correlation coefficients, a regression analysis was performed. A mathematical model of the studied dependence is presented, regression equations are derived. The analysis of the model proved that it works. The results obtained from the study aim to optimize a method for constructing a garment from a knitted fabric containing elastomeric threads.

1. Introduction

The discovery of the elastomeric thread ushered in a new era in the clothes manufacturing with the tendency for the increase of the comfort of in women’s outerwear clothing by using fabrics with more elasticity and extensibility. This is achieved with knitted fabrics containing elastane. This type of material satisfies the needs of the customers by ensuring freedom of movement while preserving their aesthetics thanks to their resilience to stretching [1,2]. The deformation properties of the knitted fabrics are especially important in the process of constructing clothing. The quality of the manufactured clothing depends on their exact determination and evaluation. This entails textile testing which further increases production costs and affects negatively the competitiveness of small businesses.

The aim of this work is to determine the deformation factors of knit fabrics with the Punto di Roma stitch structure. Based on the proven statistical significance of the correlation coefficients, a regression analysis was performed. A mathematical model of the studied dependence is presented, regression equations are derived.

2. Materials and methods

It is known that the physical properties of fabric change depending on the yarn content and knitting. According to a study of the main properties of 687 articles of knit fabrics, containing 1956 patterns which were on display on the European market from 2016 to 2020, the most commonly used knits were



jacquard – 36.6%, single jersey – 28.37%, Punto di Roma – 11.47% and others – 23.56%. 96.1% of the Punto di Roma articles contain elastane which is the most of any knit type mentioned above. The content of elastane in the knit fabrics of women's outerwear clothing is 1% to 9%, while 86.7% of the fabrics contain 2% to 6% elastane. Based on this analysis, knit fabrics with Punto di Roma stitch structure containing 2% to 6% elastane have been chosen as the subject of this study. There are multiple methods for determining the deformation factors but not all of them can be carried out on knit fabrics. A study examining these methods found that they can be classified depending on the way of applying the stress, the type of material and whether they are standardized or not [3, 4, 5, 6, 7, 8]. Strength testers with linear growth of the deformation were found to be most commonly used. The biggest differences come from the tested models and the applied force. A number of manufacturers like Marks & Spencer, Du Pont Ltd, NEXT Ltd use their own criteria, standards and methods for testing [8, 9]. There exist also express-methods for determining the stretch which produce satisfactory results despite not being scientifically proven [10, 11, 12]. A study on knit fabrics with elastane threads from Penelope Watkins found that a test with force of 2.5N supplies satisfactory results for the needs of clothing designers [9].

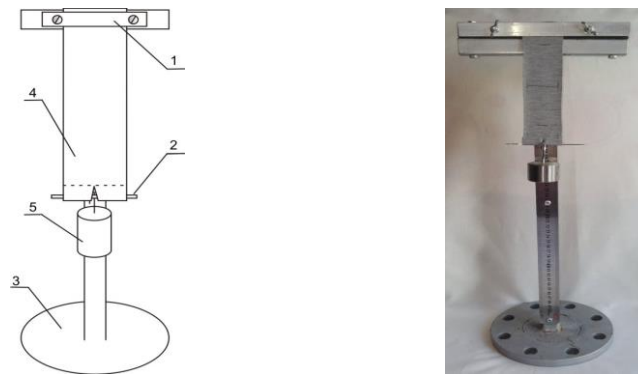

Figure 1. Test stand.

To conduct the tests a stand was developed where 1 – tightening device, 2 – fixing dowel, 3 – stand, 4 – studied sample, 5 – loading weight [Figure 1]. The applied force is 3N. It has been determined according to the elastane content of the fabric [4]. The type and the strength of the correlation between the elastane content and the deformation properties has been studied using correlation analysis. This method provides an objective measure for the correlation between the studied variables. The dependence has been studied using linear regression. The statistical analysis was performed using the Statistica 7.0 software. Statistical significance is achieved when the value of the result p is less than 0.05.

3. Experimental determination of deformation properties of Punto di Roma Jersey fabrics

Ten types of Punto di Roma Jersey fabrics have been studied. The fabrics are of yarn with similar content of elastane from 2% to 6%. For every value of elastane content two articles have been used shown below as sample 1 and sample 2. Their extensibility in the direction of the courses, wales and bias has been established. The main characteristics of the articles have been shown in table 1.

Out of every type of fabric have been cut out 5 samples with size 200mm by 50mm. The schema of the method for cutting the samples is shown on Figure 2. One end of the sample is folded. The fold is sewn 10 mm from its end with stitch type 401. A gap of 8mm length is cut out at the center of the fold. A section of length 100mm is marked at 1cm over the stich of the fold, in the middle of the sample. At the middle of the marked section, perpendicular to it is marked a section of length 40mm (fig.3). The samples are left on a horizontal surface for 30 min. Before carrying out the tests all samples are condition for 4 hours in an atmosphere of $20 \pm 2^\circ\text{C}$ with relative moisture $65 \pm 4\% \text{RH}$.

Table 1. Main characteristics of the fabrics.

Punto di Roma Jersey fabrics				
Elastomeric threads - [%]	Sample	Article	weight [g/m ²]	Yarn composition
2%	Model 1	Coimba	274,51	Polyester 69%, Viscose 29%, Elastane 2%
2%	Model 2	Clerici	240,00	Polyester 69%, Viscose 29%, Elastane 2%
3%	Model 1	Emeral Des	283,30	Polyester 29%, Viscose 68%, Elastane 3%
3%	Model 2	Cluj	250,60	Polyester 33%, Viscose 64%, Elastane 3%
4%	Model 1	Claviere	282,76	Polyester 68%, Viscose 28%, Elastane 4%
4%	Model 2	Casper	266,67	Polyester 72%, Viscose 24%, Elastane 4%
5%	Model 1	Clia DES	286,20	Polyester 73%, Viscose 22%, Elastane 5%
5%	Model 2	Connie	234,48	Polyester 63%, Viscose 32%, Elastane 5%
6%	Model 1	Clepton Des	260,87	Polyester 54%, Viscose 40%, Elastane 6%
6%	Model 2	Raimbow	231,00	Polyester 69%, Viscose 29%, Elastane 6%

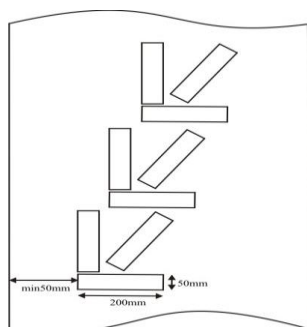
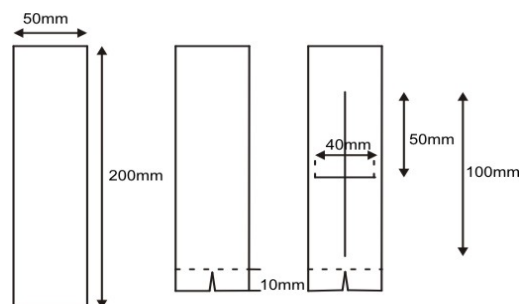

Figure 2. Scheme of the method for cutting samples.



Фиг.3. Scheme of preparation of the samples for testing.

The sample is fixed onto the stand. The fixing dowel is pushed through the stitched part of the sample and the weight is applied. The samples are stretched for a duration of 60 seconds. The lengths of the marked sections are measured. The samples are taken down from the stand and placed on a horizontal surface for 60s. The marked sections are then measured again. The stretch and the residual deformation are measured according to the following formulae:

$$\varepsilon = \frac{L_1 - L_0}{L_0} \cdot 100 [\%] \quad (1)$$

$$\varepsilon_r = \frac{L_2 - L_0}{L_0} \cdot 100 [\%] \quad (2)$$

where:

L_0 – the initial size of the sample; L_1 – the length during the loading, L_2 – the length after the 60 seconds of relaxation, ε – the relative stretch, $\varepsilon_{y,d}$ – residual deformation.

The study results show that the stretch is biggest along the course – from 35.1% to 55.8%, followed by the stretch along the bias (45%) – from 30.5% to 50.7%, the lowest is the stretch along the wale – 20.5% to 41%. The residual deformation along the three directions is from 0.15% to 1.2%. The average values of the stretch and residual deformation are show in table 2.

Table 2. Average values of stretch and residual deformation.

Elastomeric thread content - [%]	Stretch along the specific direction - [%]			Residual deformation along the specific direction - [%]		
	Course - \bar{x}	Wale - \bar{x}	Bias 45° - \bar{x}	Course- \bar{x}	Wale - \bar{x}	Bias 45° - \bar{x}
2%EL	35,1	20,5	30,5	0,3	0,5	0,5
3%EL	41,4	26,6	36,5	1	0,5	0,8
4%EL	46,3	31,5	41,5	0,2	0,3	1
5%EL	50,2	35,2	45,2	1	0,1	0,5
6%EL	55,8	41,0	50,7	1,4	0,7	1,2

The results show that the biggest maximum values (20%) for the *напречната деформация* of the fabrics are observed with the samples taken along the bias of 45°, followed by the samples cut along the course (8,8%) and wale (7.2%). The residual deformation has again low values – from 0.1% to 0.3%. As the residual deformation is lower than 2% it will not be accounted for when the parameters for construction are determined, according to the studies in this field [13, 10]. The results from these studies are displayed on table 3.

Table 3. Average values of transverse and residual deformation of knitted fabric.

Elastomeric thread content - [%]	Transverse deformation along the specific direction - [%]			Residual deformation along the specific direction - [%]		
	Course - \bar{x}	Wale - \bar{x}	Bias 45° - \bar{x}	Course- \bar{x}	Wale - \bar{x}	Bias 45° - \bar{x}
2%EL	6,6	6,6	14,3	0,1	0,1	0,1
3%EL	7,7	4,4	9,3	0,2	0,2	0,3
4%EL	8,8	6,7	20	0	0,2	0,3
5%EL	6,7	5,9	11,9	0,2	0,2	0,1
6%EL	6,5	7,2	16,5	0	0,1	0,1

To determine the correlation between the stretch, transverse deformation and the content of the elastomeric threads in the fabrics are developed and analyzed (fig.4 and fig.5). There is no significant correlation between the *напречната деформация* and their content of elastomeric threads. Analyzing the correlation between the stretch of the fabrics and their content of elastomeric threads shows a positive linear correlation.

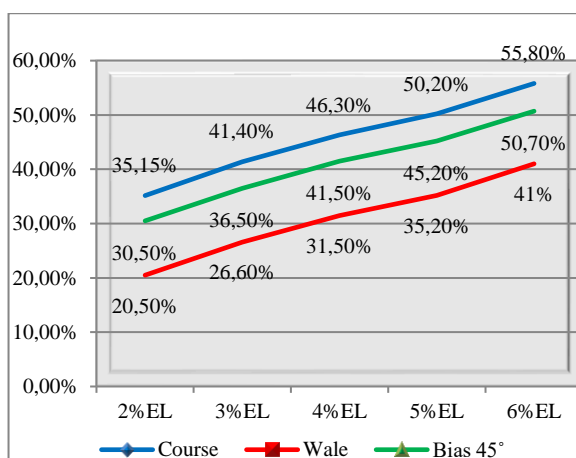
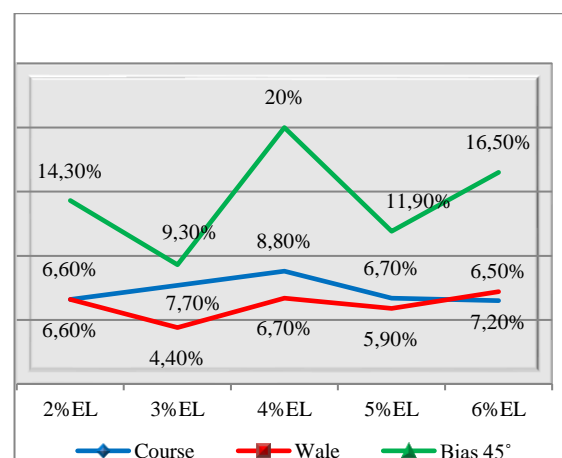
**Figure 4.** Correlation between stretch and content of elastomeric threads [%].**Figure 5.** Correlation between transverse deformation – content of elastomeric threads [%].

4. Research on the relation between the percentage of elastomeric treads and the stretch of Punto di Roma jersey fabrics

The established dependence between the stretch of the knitted fabrics and their content of elastomeric threads gives grounds on which to be studied its type and strength. Correlation analysis is used for this purpose. The standard deviation is measured in accordance to these three methods:

- Indirect - the absolute values of the asymmetry and the skewness of the sample and their standard errors are compared.
- Graphical analysis –the histograms are symmetrical and resemble the standard deviation. They are shown on figures 6, 8, and 10.
- Frequentist test – the Shapiro-Wilk tests is used as the sample size is less than 60 [14,15].

According to the results from these three methods the distribution of the data resembles the normal distribution.

Scatter plots are built to establish the shape of the distribution. They show linear correlation between the content of elastomeric threads in knitted fabrics and their stretch. The scatter plots are shown in figures 7, 9, and 11.

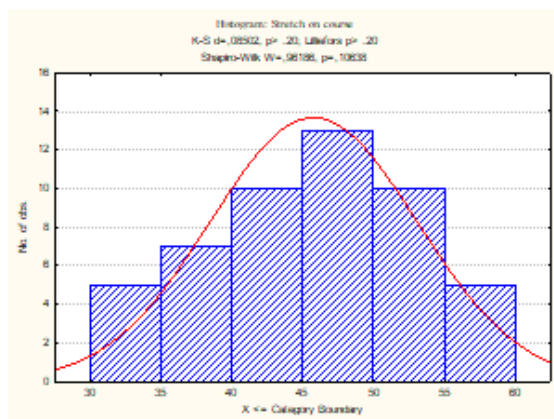

Figure 6. Histogram of the distribution of the stretch along the course.

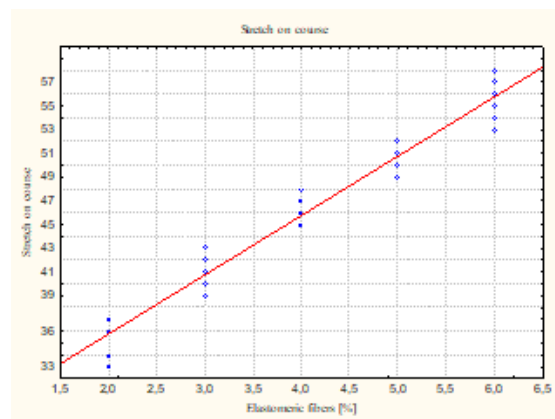

Figure 7. Correlation between the content [%] of the elastomeric threads and the stretch along the course.

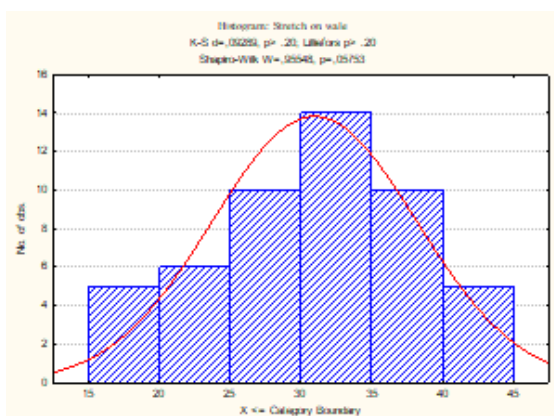

Figure 8. Histogram of the distribution of the stretch along the wale.

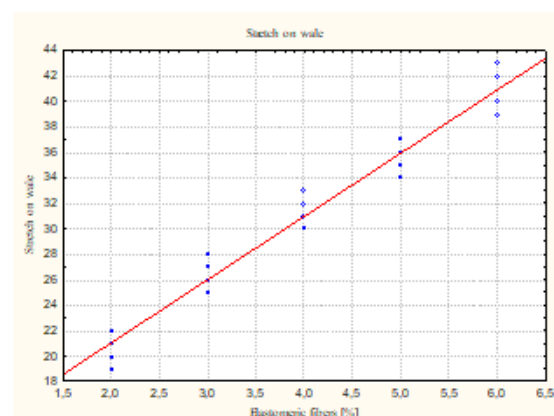

Figure 9. Correlation between the content [%] of the elastomeric threads and the stretch along the wale.

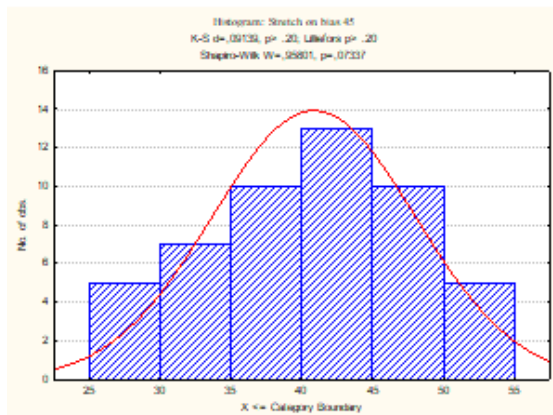

Figure 10. Histogram of the distribution of the stretch along the bias (45°).

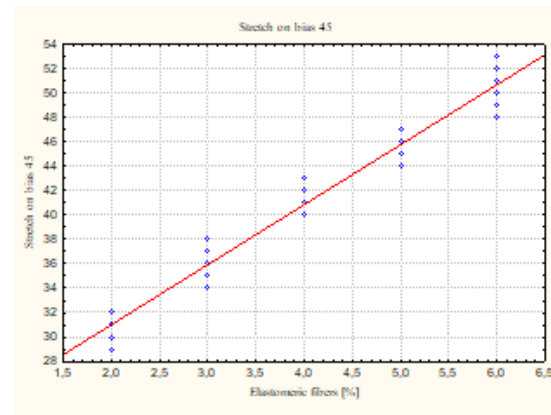

Figure 11. Correlation between the content [%] of the elastomeric threads and the stretch along the bias (45°).

The analysis results show that it is appropriate to study the correlation using parametric tests. The strength of the dependence is calculated using the Pearson correlation coefficient - r_{xy} .

The values of the correlational coefficients determine the strength of the relationship between the variables as very high. Cohen's d is used for their interpretation [14,15]. The statistical correlation is measured using Student's t -test. The results are shown in table 4. The test has $n - 2$ degrees of freedom and the statistical significance $\alpha = 0.05$.

Table 4. Analysis of the correlation coefficients.

Stretch	r_{xy}	r^2	k^2	t_R	t_T	$t_R > t_T$
Along the course - %	0,98	96,04	3,96	33,96	2,011	33,96>2.011
Along the wale - %	0,98	96,04	3,96	33,96	2,011	33,96>2.011
Along the bias 45° - %	0,98	96,04	3,96	33,96	2,011	33,96>2.011

Were: r_{xy} - Pearson coefficient; r^2 - coefficient of determination; k^2 - undetermined coefficient.

Note: The critical value of the Pearson coefficient with $n=50$ and $\alpha=0.05$ equals 0.27.

The coefficients show that 96.04% of the increases in the dependent variable are due to increases in the independent variable and the other 3.95% are due to factors not included in the analysis. The statistical dependence between the correlation coefficients are sufficient grounds to perform regression analysis with a linear regression equation.

5. Regression analysis of the correlation between stretch and content of elastomeric threads in knitted fabrics

The aim of the regression analysis is to examine and model the dependence between the percentage content of elastomeric threads in knitted fabrics and their stretch along a specific direction. Due to the high correlation coefficients and positive linear correlation, the correlation can be represented through a linear regression model [16, 17]. The stretch along a specific direction is chosen as the dependent variable and as an independent variable – the percentage content of elastomeric threads.

The linear regression model is as follows:

Regression model:

$$\varepsilon_i = \beta_0 + \beta_1 \cdot Ef\%_i + e_i \quad (3)$$

Regression equation:

$$\hat{\varepsilon} = \beta_0 + \beta_1 \cdot Ef\% \quad (4)$$

where:

ε_i – empirical values of stretch along a specific direction; β_0 и β_1 – parameters of the linear regression model; $Ef\%$ – empirical values of the percentage content of elastomeric threads; e_i – residual; $\hat{\varepsilon}$ – predicted value of the dependent variable.

The result is estimated using simple least squares regression. The calculation is performed using Microsoft Excel 2007 and Statistica 7.

The following regression equations are derived from the analysis:

$$\text{Stretch along the course:} \quad \varepsilon_c = 25,76 + 5 Ef\% \quad (5)$$

$$\text{Stretch along the wale:} \quad \varepsilon_w = 11,12 + 4,96 Ef\% \quad (6)$$

$$\text{Stretch along the bias (45°):} \quad \varepsilon_{45^\circ} = 21,16 + 4,92 Ef\% \quad (7)$$

where:

ε_c – stretch along the course, ε_w stretch along the wale, ε_{45° – stretch along the bias (45°), $Ef\%$ – content of elastomeric threads in the knitted fabric [%].

The results show a high value of statistical significance $p \leq 0,000$ and determination coefficients: stretch along the course 0.958, along the wale 0.965, and along the bias 0.963. The standard deviations are derived. The analysis is performed using the method of least squares. The results are shown in table 5.

Table 5. Standard deviation and analysis using the least squares methods.

Model of the dependent variable:	$\sum_{i=1}^n (\varepsilon_i - \hat{\varepsilon}_i) = 0$	$S_\varepsilon = \sqrt{\frac{\sum (\varepsilon_i - \hat{\varepsilon}_i)^2}{n - p}}$
Stretch along the course	2288 - 2288 = 0	1,51%
Stretch along the wale	1548 - 1548 = 0	1,37%
Stretch along the bias (45°)	2042 - 2042 = 0	1,40%

The parameters of the regression equations are statistically significant with risk of error 0.05%. The interval values β_1 are determined on the basis of the standard error of the coefficient μ_{β_1} . The interval scores are determined with probability of 95% and the value of Student's coefficient $t_{\text{табл.}} = 2.2$. The interval scores of the regression coefficients for each model are as follows:

$$\text{Stretch along the course:} \quad 4,695 \leq \beta_1 \leq 5,305 \quad (8)$$

$$\text{Stretch along the wale:} \quad 4,683 \leq \beta_1 \leq 5,237 \quad (9)$$

$$\text{Stretch along the bias (45°):} \quad 4,637 \leq \beta_1 \leq 5,203 \quad (10)$$

The analysis has shown that the regression models are adequate.

6. Conclusion

The results of the study allow for the following conclusions:

- The residual deformation of the knitted fabrics in each of the study cases is below 2%. Due to this the deformation properties of the materials during clothing construction can be examined using their stretch.
- It is established that there is no clear correlation between the deformation along the course and their percentage content of elastomeric threads.
- It is established that there is a linear correlation between the stretch and the content of elastomeric threads.
- Using linear regression it is established that increasing the percentage content of elastomeric threads with 1% with probability 0.95 can lead to expected stretch increase along the course of 4.695% to 5.305%, along the wale from 4.683% to 5.237% and along the bias (45°) from 4.637% to 5.203.

The derived mathematical models correspond to the change of stretch of knitted fabrics depending on their percentage content of elastane in the yarn allowing the possibility of a new approach for determining the deformation properties of the knitted fabrics with elastane when pattern making garments. This could allow clothing designers to determine these properties using the fabrics data given by clothing manufacturers according to the standards for labeling of textile products.

Acknowledgments

This work was supported by the Trakia University, Bulgaria under Project 2.FTT/ 22.05.2018.

References

- [1] Poincloux S 2019 Élasticité et tremblements du tricot (<https://www.researchgate.net/publication/329555093> accessed Aug 23 2019)
- [2] Dolapchieva, G 2003 *Research and improvement of the methodology for construction of tight-fitting clothing from knitted fabrics*, Dissertation for PhD, TU-Gabrovo (in Bulgarian)
- [3] ASTM D3107-07(2019) Standard Test Methods for Stretch Properties of Fabrics Woven from Stretch Yarns
- [4] BDS EN 14704 - 1: 2006 Determination of fabric elasticity
- [5] BS 4952:1992 Methods of test for Elastic fabrics
- [6] GOST 8847-85 Knitted fabrics Methods for determining the rupture characteristics and elongation at loads less than rupture
- [7] Kyzymchuk O, Melnyk L *Stretch properties of elastic knitted fabric with pillar stitch* (Journal of Engineered Fibers and Fabrics October-December: 1–10)
- [8] Standard NEXT TM 21a (knit)
- [9] Watkins P A 2011 *Designing with stretch fabrics* (Indian Journal of Fibre & Textile Research Vol. 36, December 2011, pp. 366-379)
- [10] I-Chin (Doris) Tsai 2001 *The influence of woven stretch fabric properties on pattern design* (Montfort Universit) (<https://core.ac.uk/download/pdf/29076217.pdf>)
- [11] Armstrong H J 2000 *Pattern Making for Fashion Design* (3rd Edition Prentice Hall)
- [12] Kovalenko EV, OA Kucharenko, MS Gorbachevskaya 2012 *Design of products from inelastic knitted fabrics* (Sewing industry №3 2012 p.42,43)
- [13] Du Pont de Nemours & Co. 1976 *How to Measure the Elastic Properties of Woven Stretchable Fabrics* (Bobbin, May, pp.1 02-111)
- [14] Dimitrov P 2003 "Introduction to Statistics" (Shumen University "Bishop Konstantin Preslavski", Shumen) (in Bulgarian)
- [15] Ganeva Z 2015 "Let's rediscover statistics with ibm spss statistics" Elestra
- [16] Stukach OV 2011 *Statistica software package for solving quality management problems* (Tomsk Polytechnic University, Tomsk)
- [17] Hill T and Lewicki P 2007 *Electronic Statistics Textbook* (<http://statsoft.com/textbook/stathome.html>)