

STAND FOR TESTING OF BI – DIRECTIONAL CONVERTERS IN PHOTOVOLTAIC SYSTEMS

Ivan Hristov, Bogdan Gilev, Nikolai Hinov

Faculty of Electronic Engineering and Technologies, Technical University - Sofia
8 Kliment Ohridski bul., 1000 Sofia, Bulgaria, phone: +359 2 965 2204, e-mail: i_hristov@tu-sofia.bg, hinov@tu-sofia.bg, b_gilev@tu-sofia.bg

Introduction

The purpose of this paperwork is to present a developed an experimental stand for testing different kinds of bi – directional circuits, providing a work of a supercapacitors in renewable energy systems – photovoltaic systems. A simulation model has been created of the studied bi – directional converter. For testing different circuit kinds of bi – directional converters in photovoltaic systems, an experimental stand, described in this work, has been created. The information measuring system is realized by the software LabView. In the document a comparison between the simulation and experimental results has been made.

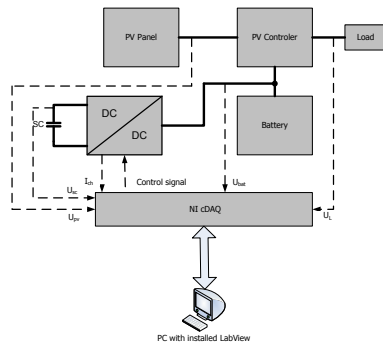

Fig.1 Block diagram of the stand for testing

1. Developing of a virtual instrument

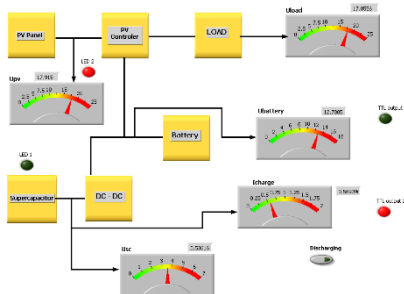

Fig.2 Front panel of the virtual instrument – control system

The measured values and the generated control pulses are displayed on the front panel of the virtual instrument. By reaching a predetermined value of the voltage over the supercapacitor, the control system generates a control signal, which stops the charge of the supercapacitor. When the voltage decrease under another predetermined value, a control pulse is generated and the charging of the supercapacitor starts again.

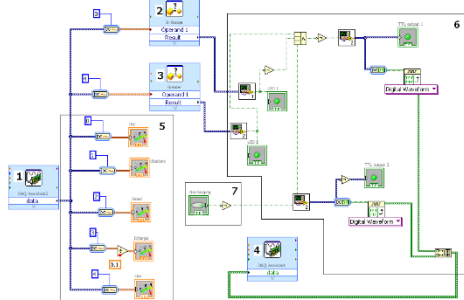

Fig.3 Block diagram of the virtual instrument

The functions of the blocks 1 to 7 are:

1. Block 1 – this is an input device (ADC-cDAQ);
2. Block 2 – this is a comparator;
3. Block 3 – this is a comparator;
4. Block 4 – this is the graphical representation of a module with TTL outputs;
5. Block 5 – graphical indicators of the scales of the voltmeters;
6. Block 6 - logical circuit for execution of the predetermined programmed working regime of the system;
7. Block 7 – it is a virtual button for manual control.

2. Studied circuit of the bi – directional converter

On figure 4 is shown the block diagram of the studied bi – directional converter. The bi – directional converter is made of two specialized integrated circuits (U1 and U2) of DC – DC switching converters.

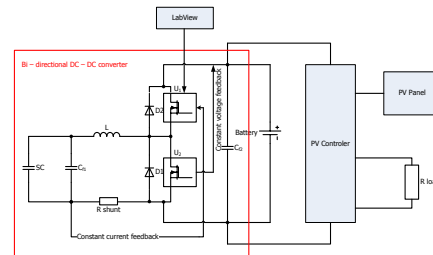

Fig.4 Block diagram of the studied bi – directional converter

3. Simulation and experimental results

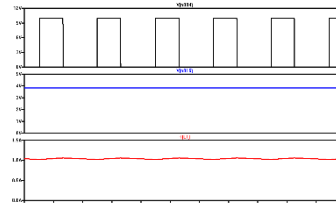

Fig.5 Simulation results of the work of the converter in charging mode.

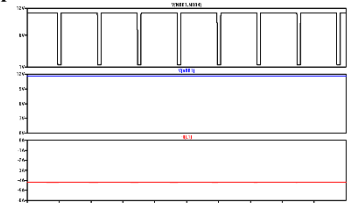

Fig.6 Simulation results of the work of the converter in discharging mode.

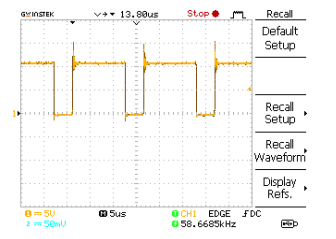

Fig.8 Experimental results in charging mode

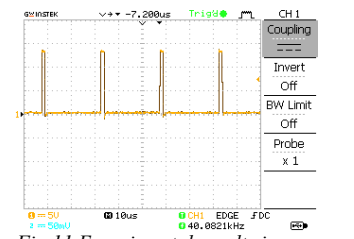

Fig.11 Experimental results in discharging mode

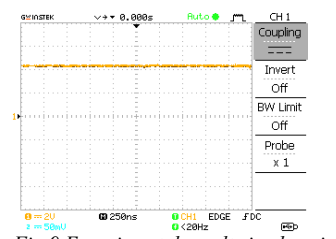

Fig.9 Experimental results in charging mode

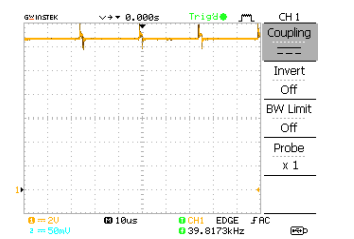

Fig.12 Experimental results in discharging mode

4. Conclusion

A universal stand for testing the combine work of a supercapacitor and battery in photovoltaic power supply system was created. The stand allows flexible programming of the working regimes of the converters on the system. We can use different kinds of converters for searching of an optimal circuits and decisions for a system by different choices. User friendly graphical interface facilitates the displaying of the process in the system and track the pros and cons of the tested circuits and systems. Adding PV simulator to the stand will allow testing the system at any time in the day and imitating of different weather conditions.

The comparison between the experimental and the simulation results, part of them are shown from fig. 5 to fig. 13, shown sufficient accuracy for the engineering methodology.

Acknowledgment

This research was funded from the Scientific and research sector of the Technical University of Sofia under contract No.142П/Д0012-03 “Study of DC – DC electric energy converters with applications in telecommunication systems.”