

Couplings of Microstrip Triangular Open-Loop Resonators

Marin V. Nedelchev¹, Ilia G. Iliev²

Abstract: This paper presents a study of the coupling topologies of microstrip triangular open-loop resonators and their application in filter design. Due to their shape, triangular resonators have many coupling topologies in order to achieve couplings of different nature—electric, magnetic, mixed. Each coupling topology is analyzed in full wave electromagnetic (EM) simulator in order to estimate the resonance peaks in the frequency response. Based on the simulation results, coupling coefficient graphs are presented. These graphs can be used in microstrip filter design.

Keywords: coupling coefficient, triangular open loop resonator, cross coupled filters.

I. INTRODUCTION

In the modern communication systems, high selectivity and low passband loss are the main requirements for the microstrip filters. Low passband loss increases the system sensitivity and the high selectivity decrease the guard interval between two channels in a communication system. Better spectrum efficiency is achieved. High filter selectivity requires high filter order and more resonators. Because of the low unloaded Q factor of the microstrip resonators, the passband loss increases. Both requirements become contradictory for cascaded microstrip filters. Filters satisfying the increased requirements are the cross-coupled filters. They have non-adjacent resonator coupling.

The synthesis of cross coupled filters is based on the early works from Atia and Williams [1], Cameron and Rhodes [2,3] considering waveguide cavity filter design. It is based on the deriving the coupling matrix from the transfer function and its reduction to the corresponding topology form. This technique is found to be useful in the design of microstrip cross-coupled filters. Generally, they are compact in size and weight, easy for manufacturing and adjustment. Therefore, there is a growing interest in the microstrip filter design.

The practical application of the design approach adopted from the waveguide filters, require knowledge about the mutual couplings between the microstrip resonators.

Triangular open loop resonators are proposed for filter design in [4]. Their geometrical form allows coupling in different coupling schemes, which exhibits various coupling types. The coupling topologies shown on Fig.1 may be used in the cross coupled filter design as well as classic filters. It is possible to form the resonator as an isosceles right-angled, isosceles or equilateral triangle, according to the desired topology.

¹Marin Veselinov Nedelchev – Assistant, PhD in Dept. of Radiotechnic in Faculty of Communications and Communication Technologies in TU –Sofia E-mail mnedelchev@tu-sofia.bg

²Ilia Georgiev Iliev – Assoc. Professor, PhD in Dept. of Radiotechnic in Faculty of Communications and Communication Technologies in TU –Sofia E-mail: igiliev@tu-sofia.bg

The optimum form depends on the filter topology, circuit size and the necessary value of the coupling coefficient. This paper describes the four basic coupling topologies, shown on Fig.1. The form of the resonator used in simulations is isosceles right-angled triangle.

Full wave EM simulator is used for obtaining the resonance frequencies when introducing electrical and magnetic walls. The coupling mechanism is described in order to achieve better comprehension of the nature and the applicability of the coupling structures. Numerical results for the values of the coupling coefficients are presented.

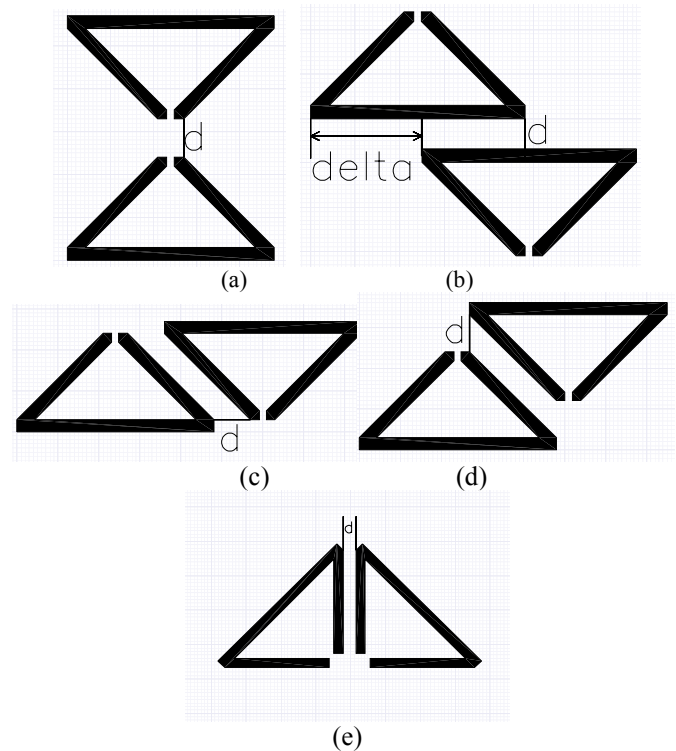

Fig.1 Topologies of triangular open loop resonators (a) electrical coupling, (b) magnetic coupling, (c), (d) and (e) mixed coupling

The obtained results are graphically shown and they are applicable for practical design.

II. TRIANGULAR OPEN LOOP RESONATOR COUPLING STRUCTURES

The triangular open loop resonator is half wavelength long for the central frequency of the filter. When constructing a filter, the exact form of the triangle should be chosen: right-angled, isosceles, equilateral or scalene. It is convenient for symmetrical filter topologies to use isosceles or equilateral

triangular resonators. More common case is to use right-angled isosceles resonators.

The coupling structures are formed by different orientation in the plane of identical resonators. They should be closely situated and separated by distance d . Both resonators in the coupling structure may have or not an offset in the direction of the coupled lines- denotes as δ (Fig.1b). This offset is made for two major reasons- to achieve loose coupling or to make possible connection of another resonator.

The coupling mechanism is based on the fringe fields of closely situated resonators. The nature of coupling depends on the resonator configuration. It is clear that half wavelength triangular resonator is symmetrical along the center of the hypotenuse. Consequently for the first resonance (odd mode), this point is an ideal short circuit (electric wall). The magnetic field will be predominant over the electric around this point. On the opposite side, the electric field will be dominant around the open ends of the resonators.

The coupling coefficient for synchronously tuned resonators can be calculated easily by the resonance frequencies of even and odd mode [5]:

$$k = \frac{f_e^2 - f_o^2}{f_e^2 + f_o^2} \quad (1)$$

The necessary condition for observing these resonance peaks is to set the resonator structure in overcoupled mode. In this case the coupling coefficient is larger than the critical coupling value of $1/Q$, where Q is the quality factor of the resonators [6]. A full wave EM simulator based on the Method of the Moments (MoM) is used to identify the resonance frequencies. Most of the coupling structures are simulated using the symmetry in their topology for electrical and magnetic wall introducing in-between. When symmetry does not present, the whole structure is simulated. This does not constrain in any way the obtained results. The simulation are carried out for standard FR-4 substrate with $\epsilon_r = 4.4$, $h = 1.5mm$, $tg\delta = 0.02$.

A. Electrical Coupling

Following the above mentioned considerations, an electrical coupling presents in the structure shown on Fig.1a. Both resonators are close each other with their open ends. Because of the triangular form of the resonators, the coupling is realized by the apexes of resonators. Despite of the strong electrical field at this point, the small proximity areas leads to very small values of the coupling coefficient.

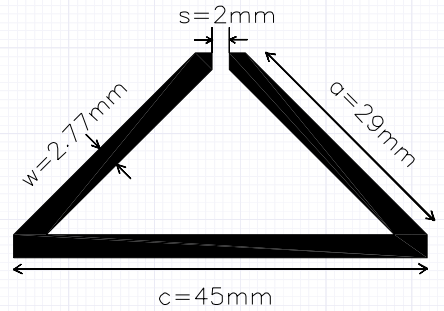

Fig.2 Triangular open loop resonator used in the simulations tuned on 811MHz

More over the sign of the coupling coefficient is negative, because the resonance frequency of odd mode (short circuit) is greater than the resonance frequency of even mode (open end) [5].

Figure 2 shows the topology of the microstrip triangular open loop resonator with the following dimensions: strip width $w = 2.77mm$, corresponding to 50Ω line on FR-4, hypotenuse length $c = 45mm$, cathetus length $a = 29mm$, gap between the cathetuses $s = 2mm$.

The first resonance frequency of the resonator is 811MHz. A number of full wave EM simulations are carried out in order to obtain the resonance frequencies in the frequency response. The coupling coefficient is calculated according to Eq.(1). The numerical results for the coupling coefficient are presented on Fig.3. It is clearly seen that the value of the coupling coefficient exponentially decays with the increase of the gap between the resonators. The results show that the coupling is very weak: the value of the coupling coefficient is about ten times less than in other coupling structures.

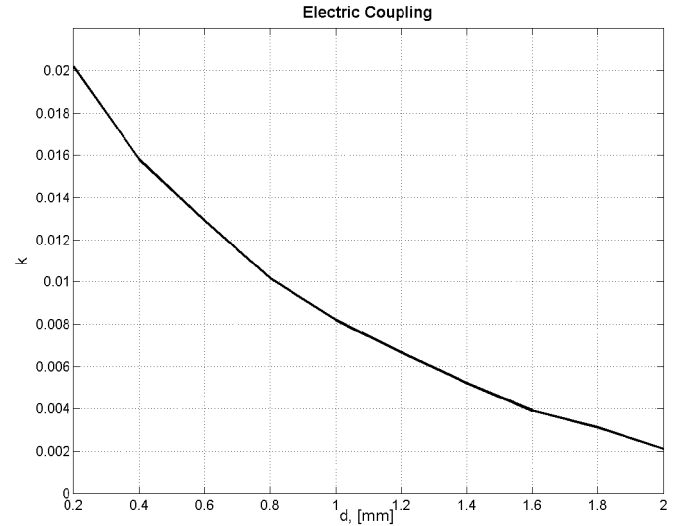

Fig.3 Coupling coefficient for electrically coupled resonators

The sign of the coupling coefficient is negative. This fact is very important for the cross coupled filters. The coupling between the non-adjacent resonators should be out-of-phase the other couplings. In the case of triangular coupled resonators, the coupling is not strong enough. This leads to transmission zeros in the frequency response away from the passband.

B. Magnetic Coupling

Magnetic nature of coupling presents in the coupling structure shown on Fig.1b, when the offset distance δ is zero. Both resonators are coupled through their hypotenuses, where short circuit is present for the resonance frequency. The magnetic field at this point is predominant over the electric. The electric field can be neglected in this case. Using the same resonator, shown on Fig.2, full wave EM simulations are carried out in order to obtain the resonance peaks in the frequency response of the coupling structure. The results are shown on Fig.4.

When $\delta = 0$, there is no offset between the resonators. The coupling nature is pure magnetic. Since the hypotenuse is the longest side of the triangular resonator, combined with the strong magnetic field, the value of coupling coefficient is high. This topology is suitable for wideband filters, while maintaining reasonable distance d between the resonators. The inconvenience of using this structures rises from the fact that the cathetuses are the only available sides for couplings. This constrains the number of filter topologies involving the coupling structure.

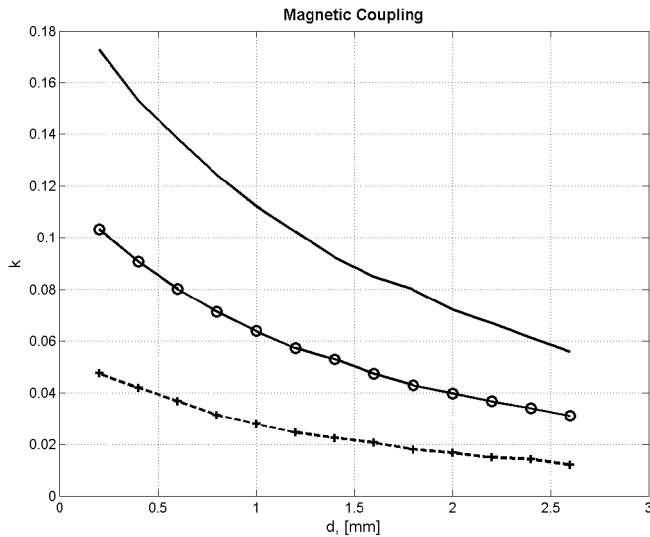

Fig.4. Coupling coefficient for magnetic coupling. Solid line- $\delta = 0$ (no offset), circles- $\delta = 0.5c = 22.5mm$, dashed- $\delta = 0.25c = 11.25mm$.

More flexible form of predominant magnetic coupling is when an offset is presented in the structure (Fig.1b). The coupling is not purely magnetic in nature because of the offset. When δ is one half of the hypotenuses, the one more side (the other side of the hypotenuses) is present for additional coupling. In this way the coupling coefficient lowers its values, but remains the monotonically decreasing behavior (Fig.4 circles).

When the offset δ is a quarter of the hypotenuses, the coupling becomes weaker (Fig.4 dashed). The character of the coupling is not longer magnetic, but mixed. This topology combines the possibility of coupling to another resonators and asymmetric filter topologies.

C. Mixed Coupling

Mixed coupling presents, when both triangular resonators are close with their cathetuses (Fig.1c,d). The coupling resonators are opposite situated in the plane. The currents in the coupled lines are equal in amplitude and in-phase. It cannot be estimated which component of the field- electric or magnetic is dominant in this coupling structure. However, the electrical field decays more rapidly with the distance from the open ends, than the magnetic field. The value of the coupling coefficient is with positive sign.

Since the coupling lines are tilted by 45° , the distance between them is hard to be controlled. There is no closed form

formulas for synthesis of microstrip coupled lines tilted by arbitrary angle. The only way for characterization them is to use a full wave EM simulator.

The approach chosen in this paper for obtaining the coupling coefficient is to fix one of the resonators and to move the other one either in horizontal (Fig.1c), or in vertical (Fig.1d) direction. This approach has an important advantage when adjusting the filter. Then it is easy to measure exactly the gap d between the resonators and to verify the coupling coefficient according to the graphical results presented here.

When horizontal spacing is introduced, the graphical results are presented on Fig.5. It is clearly seen that the value of the coupling coefficient decreases with increasing the spacing between the resonators.

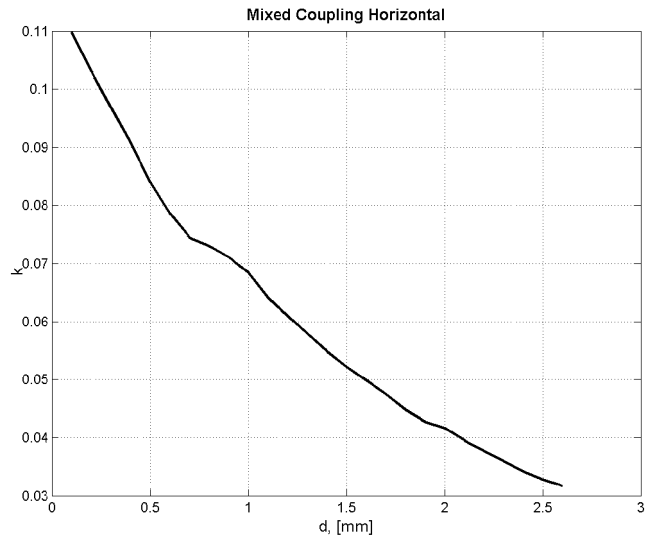

Fig.5 Mixed coupling with spacing in horizontal direction

The graphical results for vertical spacing between the resonators (Fig.1d) are presented on Fig.6.

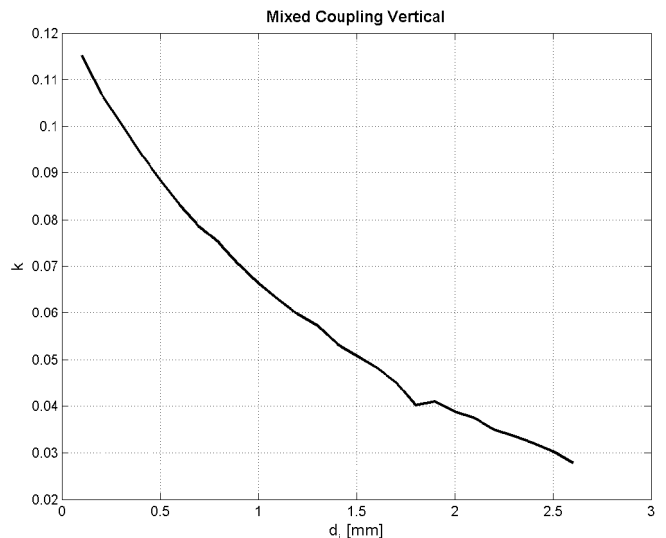

Fig.6 Mixed coupling with spacing in vertical direction

The coupling coefficient has the same behavior as the coupling coefficient for horizontal spacing.

The mixed coupling presents in the coupling structure shown on Fig.1e. As it is seen both resonators are coupled with their cathetuses and they are parallel in the plane. The

currents in the coupled lines are equal in amplitudes, but out-of-phase. This fact supposes low value of the coupling coefficient. The coupling structure is simulated in full wave EM simulator according to the above described method and the resonance peaks' frequencies are obtained. The graphical results are presented on Fig.7.

As it is clearly seen, the magnetic and electric field acts in opposite directions. This leads to coupling coefficient values about two times less than in the topologies shown on Fig.1 (c and d). It is reported in [5,7], that the coupling coefficient for this type of mixed coupling has not monotonic behavior. This is the case when the electric and magnetic field annihilate each other. Then the coupling coefficient could be zero [7].

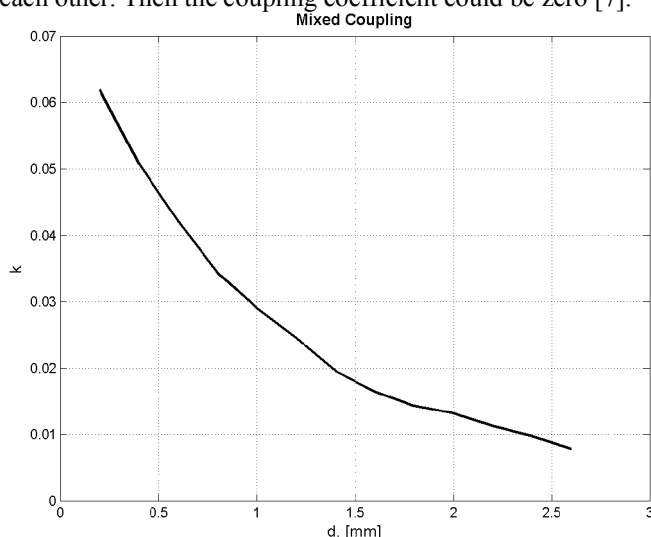

Fig.7 Mixed coupling for the structure shown on Fig.1e.

The coupling coefficient for the structure on Fig.1e has two times faster decreases than the other coupling coefficients. For the investigated region of spacing $d = (0.2 \div 2.6)mm$, the coupling coefficient decreases more than 6 times. The corresponding coupling coefficient for mixed coupling structure shown on Fig.1c and d decreases 3.5 times. The magnetic coupling with $\delta=0$, $\delta=0.5c$ and $\delta=0.25c$ decreases around 3 times. The electric coupling the “dynamic range” of the coupling coefficient is about 10 times.

This observation may be taken into account, when consider the sensitivity of the coupling structures with the manufacturing tolerances and the impact of the adjustment of the couplings on the overall response of the filter. It is seen that the weak couplings lead to higher sensitivity to the spacing tolerances.

The presented graphs for different coupling structures of microstrip triangular open loop resonators can be used in the filter synthesis, when FR-4 substrate is utilized.

V. CONCLUSION

This paper presents a survey of the coupling coefficient for microstrip triangular open loop coupled resonators. The form of the resonator used is isosceles right-angled triangle. There are described the four basic coupling topologies with electric, magnetic and mixed coupling. The coupling mechanism is described in order to achieve better comprehension of the

nature and the applicability of the coupling structures. In order to characterize the coupling coefficient, a full wave EM simulator is used for obtaining the resonance frequencies when introducing electrical and magnetic walls. Numerical results for the values of the coupling coefficients are presented. The numerical results can be used in cross coupled filter synthesis.

REFERENCES

- [1] A.E. Atia and A.E. Williams. "Narrow-Bandpass Waveguide Filters." 1972 Trans. on Microwave Theory and Techniques 20.4 (Apr. 1972 [T-MTT]): 258-265
- [2] Cameron, Rhodes, J.D., Asymmetric Realization for Dual-Mode Bandpass Filters, IEEE Trans on MTT 1981 Jan., pp.51-58
- [3] Cameron, R., Advanced Coupling Matrix Synthesis Techniques for Microwave Filters, IEEE Trans on MTT-50, Jan.2003, pp.1-10
- [4] A. GÖRÜR, and C. KARPUZ, "Cross-coupled bandpass filter using microstrip triangular open-loop resonators", Proceedings of 31th The European Microwave Conference, CD-ROM, Sep 24-28, 2001, Excel, London, ENGLAND
- [5] Hong J.-S. , M.J. Lancaster. "Couplings of Microstrip Square Open-Loop Resonators for Cross-Coupled Planar Microwave Filters." 1996 Transactions on Microwave Theory and Techniques 44.11 (Nov. 1996 [T-MTT]): 2099-2109.
- [6] Matthaei, G., Young, L., Jones, E.M.T., Microwave Filters, Impedance-Matching Networks, and Coupling Structures, Artech House, Norwood, MA, 1980
- [7] Nedelchev, M., Coupling Coefficient analysis in synchronously tuned square open-loop microstrip filters. Electronics and Electrotechnics Journal, 2005 (in Bulgarian)