

Improvement Of Metrological Characteristics Of Air Gauge Systems For Linear Dimensions

Miroslav Hristov¹

¹*Mechanical Engineering and Instrumentation, Technical University, Sofia, Bulgaria*

Abstract- Air gauges (AGS) are widely applicable in series production and, in particular, in the automotive industry. Modern AGSs have more and more communication capabilities. Despite these improvements, some of their disadvantages remain unresolved - the need for calibration at start-up, the mistakes caused by supply pressure fluctuations, and the need for highly qualified staff. The advanced communication capabilities of AGSs for connection with PCs, computer based systems, PLCs, and others can greatly facilitate the calibration process while improving the metrological and operational performance of the systems. The current study presents the influential factors and methodology for improving the metrological and operational characteristics of AGS. These studies should facilitate the IPR calibration process by introducing software compensation. A one-off initial study of the instrument allows the introduction of software compensations for errors of non-linearity and supply pressure, which improves its metrological and operational performance. By means of the tests made, it is possible to facilitate the AGS calibration methodology by reducing the number of required reference values for adjustment, which has a direct economic effect. Facilitated calibration results in a reduction of the operator's influence on the measurement result and an increase in its performance.

Keywords – air gauges, improvement, measurement systems, calibration, software

I. INTRODUCTION

Air gauges (AGS) are widely applicable in series production and, in particular, in the automotive industry. In this sector, the advantages of AGS are at the forefront, but one of their main disadvantage - the need for calibration at start-up - remains a problem. The need for calibration leads to the requirement for highly qualified staff. Another significant disadvantage is associated with the supply pressure fluctuations causing an error in the measurement result. The advanced communication capabilities of AGSs for connection with PCs, computer based systems, PLCs, and others can greatly facilitate the calibration process while improving the metrological and operational performance of the systems. This reduces subjective error and increases accuracy.

The purpose of this study is to identify the influence factors and improve their metrological and operational performance. These studies should facilitate the AGS calibration process by introducing software compensation.

II. SCHEME FOR TESTING OF AIR GAUGE SYSTEM FOR IMPLEMENTATION OF SOFTWARE COMPENSATION.

The main factors influencing the AGS are the fluctuations in the supply pressure and the subjective factor - system calibration by the operator. An experimental setting presented in Figure 1 was used to study factors of influence. To supply the AGS, we use degreased air from compressor 1 that runs through an air dryers 2 and a filter group 3 (SMC-AFJ). Pressure is regulated by a pressure regulator 4 (SMC AR20) and read by a digital pressure sensor 6 (SMC PSE 300). The signal is converted from a myRIO Student Embedded Device analog-to-digital converter and exported to a computer 7, which software compensates for the supply pressure fluctuations and the converter's non-linearity. [4, 5]

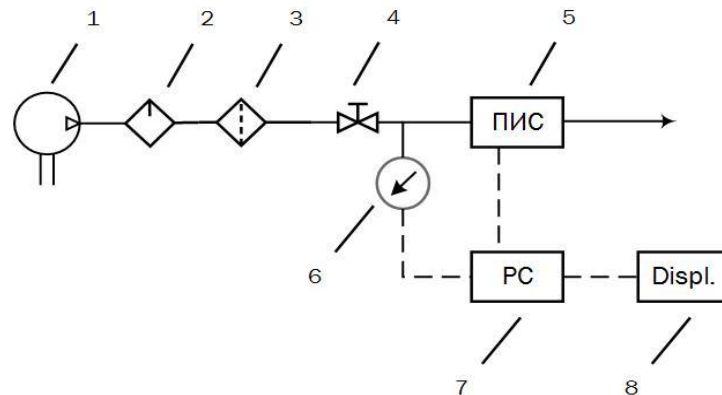

Figure 1. Block diagram experimental setting

The investigations are carried out with an Air-electronic gauges IBR-ae1 and we accepted limitations of the operating conditions. A measuring range of $\pm 25\mu\text{m}$ is selected. The behavior of the measuring system shall be tested at a change in supply pressure within ± 0.25 atm. The change of the supply pressure is carried out by means of a digital pressure sensor SMC PSE 300. The resulting signal is converted by a National Instrument - myRIO Student Embedded Device to be used as PC input data (Figure.2) [2, 3]

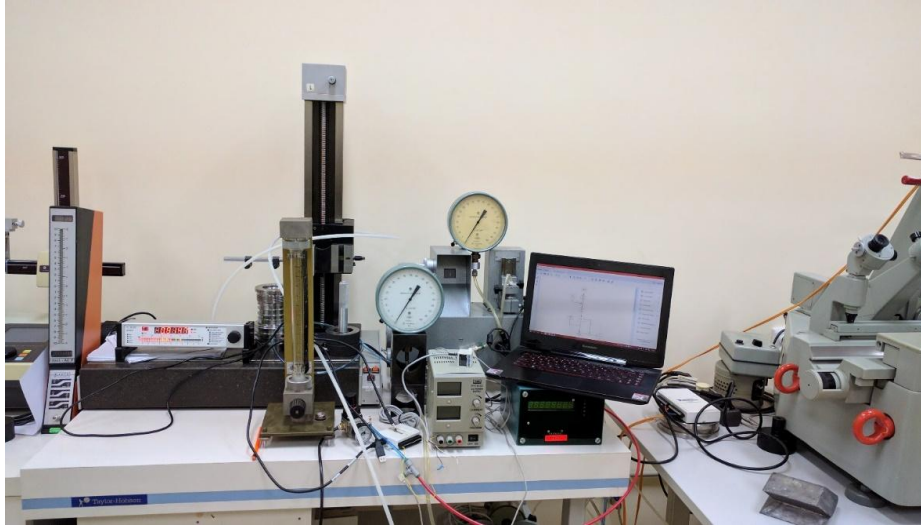

Figure 2. Experimental setting

The change of the input parameter is set by Universal length measuring instruments. For air gauge measuring equipment, we use a measuring nozzle with diameter 1.5 mm.

III. STUDY OF FACTORS OF INFLUENCE ON THE METROLOGICAL CHARACTERISTICS OF AGS

One of the main factors influencing the metrological characteristics of AGS is the fluctuation of the supply pressure. It directly affects the accuracy of the measuring system and the need for calibration at start-up. Monitoring and compensating for change of supply pressure is one of the main goals. [1, 2]

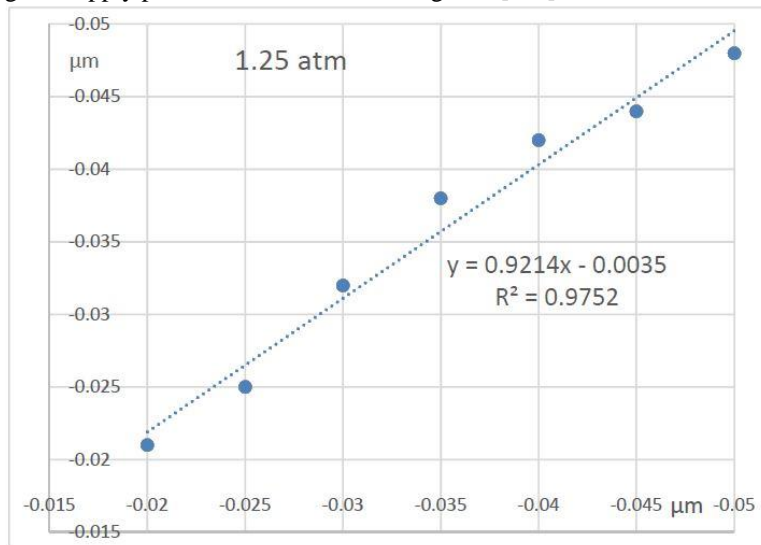

Figure 3. Conversion function - IBR ae1 to linear displacement [μm] for inlet pressure 1.25 atm.

The nonlinearity of the function of the transformation depends on the supply pressure selected by the instrument calibration and the change of the inlet nozzle section (d_1) of the AGS. [2]

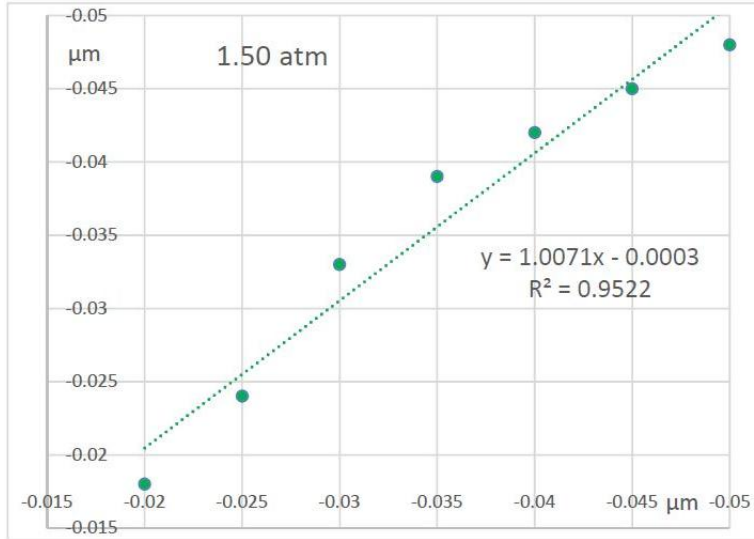

Figure 4. Conversion function - IBR ae1 to linear displacement [μm] for inlet pressure 1.5 atm.

Calibration of AGS goes through several consecutive stages and iterations to achieve maximum accuracy. Most often, this process is related to the use of two reference values, such as caliber, ring gauges, etc. The values of the reference elements are selected in such a way as to cover 60-80% of the measurement range. They are insufficient to achieve minimal non-linearity of the transformation characteristic. To reduce the nonlinearity of the characteristic, it is necessary to use a third - intermediate reference value and adjust the inlet nozzle section (d_1) of the AGS. [1, 3, 5]

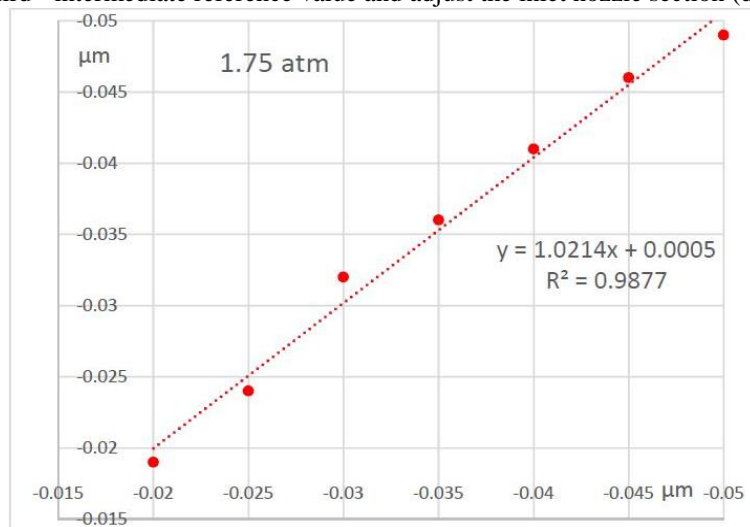

Figure 5. Conversion function - IBR ae1 to linear displacement [μm] for inlet pressure 1.75 atm.

To determine the nature of the conversion function, we conduct a study at three different supply pressure values covering the predetermined range of ± 0.25 atm. From the obtained experimental results we define a linear regression model (Figure 3,4,5) of the transformation function. The coefficients of the regression models are very close, allowing an average of the coefficients to be used for the whole range of the study. This results in a maximum error at the edges of the measuring range, which does not exceed 1.5%. This systematic error of the model is at the expense of simplified determination of software compensation coefficients and uniformity of the method of application for different AGSs. [2, 5]

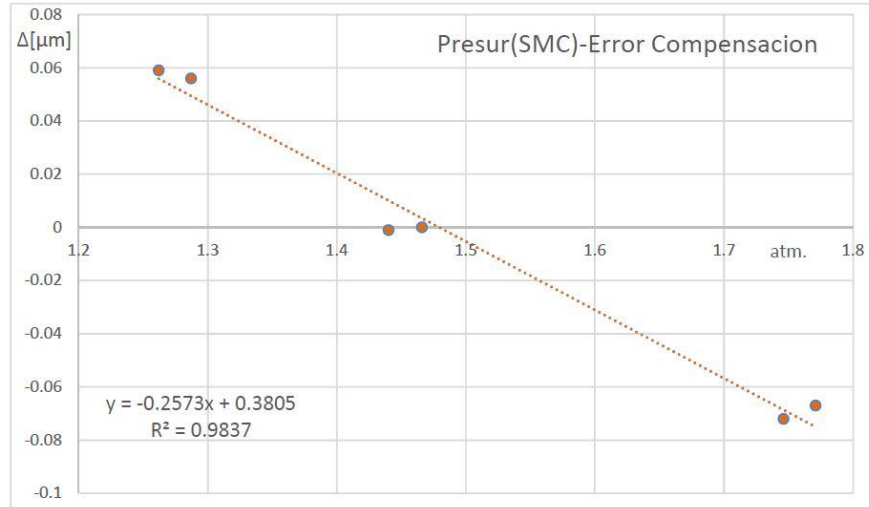

Figure 6. Graph of change in IBR ae1 indication as a function of inlet pressure.

The values of the regression coefficients are entered directly into the software for compensating non-linearity. To obtain regression coefficients, it is necessary to pre-examine the device at three different values of the supply pressure (Figure 6). The specific pressure values do not matter, it is only necessary that they cover a maximum part of the range of change. In order to compensate for the supply pressure fluctuation, a differential model is used, which only takes into account the value of its change compared to the previously entered zero (reference) value. In order to achieve the universality of the method, it is necessary to examine the characteristic obtained after the AGS setup by using reference values and supply pressure readings that are input into the computer processing information. (Figure 7)

IV. ALGORITHM FOR SOFTWARE ENHANCEMENT OF AGS FEATURES

The Software Compensation Method goes through several steps to work with the AGS. It is necessary to record the instantaneous values of the reading device when performing the calibration against the reference element as well as the pressure at which this calibration is performed. These values serve as a zero point to follow the change in input value and pressure variation.

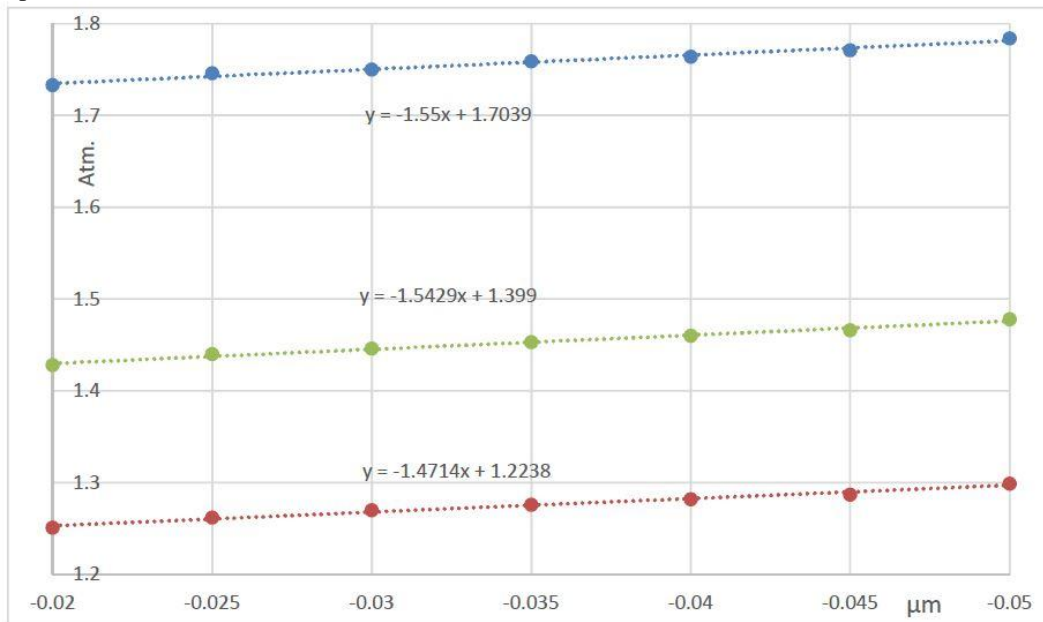

Figure 7. Family curves as a function of the value of IBR ae-1 to linear displacement at charge of inlet pressure.

In advance are set changes of the working pressure and the measuring range. This limits the capabilities of the device, but at the same time reduces the operator's influence and excludes the possibility of fatal errors.

According to the supply pressure values, three cases can be considered. The simplest case in which the measuring system may come into operation is when the value of the digital pressure gauge is equal to the reference value recorded by the software as a zero point. In this case, the value of the IBR is reported as the adjusted value without introducing compensation.

In the next case, we have a variation of the pressure corresponding to the change of the input magnitude in the set measuring range. This option introduces a correction to compensate for the non-linearity error of the pneumatic transducer.

In the most general and most complex case a change in the supply pressure is observed greater than the change in the measuring range but within the predefined limits. Compensation in this case is complex by first recalculating the transducer's non-linearity and the corresponding pressure variation, while the remainder compensates for the error caused by the change in supply pressure. In order to achieve optimal results, the supply pressure variation interval is divided into two parts - from the reference pressure value to the maximum allowed and from the reference value to the minimum allowable pressure.

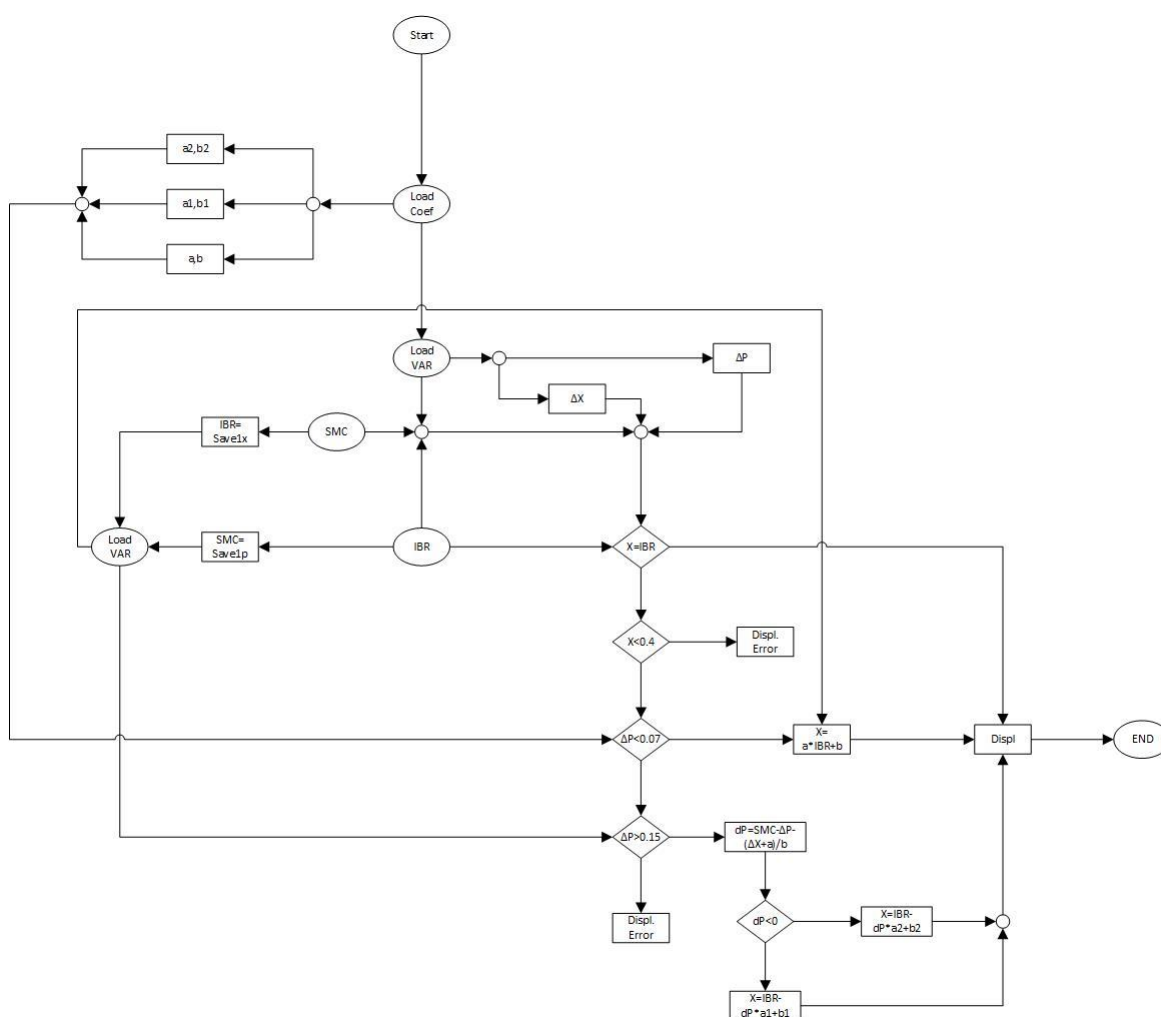

Figure 8. Block diagram for software compensation.

Compensation requires the input of coefficients for software compensation. There are three pairs of coefficients that are obtained by regression analysis of the studied initial transformation characteristics of the AGS. The input of these coefficients in the system or their automatic software calculation makes the method a universal tool for various devices includes a PC interface.

With obtained results and the presence of feedback from the digital pressure gauge make it possible to minimize the error of the supply pressure fluctuation. Within an interval of ± 0.25 atm. the change causes an error of the order of 0.04-0.08 mm. In practical conditions and in the presence of a pressure stabilizer this oscillation is in the range of $1 \div 3 \mu\text{m}$.

Combination of the compensation of non-linearity and the supply pressure fluctuation results in the improvement of the metrological characteristics by up to 10%. This includes the systematic error of the mathematical model, which can be compensated by introducing point compensations through the "Error Map"

To facilitate the AGS calibration process, we take the inlet nozzle section (d1) as constant so that the operator does not need to change it at startup and at the start of the work shift. This also gives the simplicity of software compensation.

This has a direct financial effect because a large amount of reference values (eg calibers, ring gauges) for the different types of measuring equipment is not needed. With a constant section of the inlet nozzle, we have the conversion characteristic dependent only on the value of the inlet pressure on the same measuring equipment.

The use of a digital pressure gauge in conjunction with a non-amplifying pressure regulator gives results that are better than those obtained with a pressure regulator with amplification.

The indirect positive effect of the system is to reduce the subjective error caused by the operator in setting of AGS.

V.CONCLUSION

A one-off initial study of the instrument allows the introduction of software compensations for errors of non-linearity and supply pressure, which improves its metrological and operational performance.

By means of the tests made, it is possible to facilitate the AGS calibration methodology by reducing the number of required reference values for adjustment, which has a direct economic effect. Facilitated calibration results in a reduction of the operator's influence on the measurement result and an increase in its performance.

VI. REFERENCE

- [1] Дюкенджиев Г., Р.Йорданов. Пневматична система за контрол на линейни размери. Сборник с доклади от Национален Симпозиум с Международно участие "Метрология и Метрологично Осигуряване '99" (Созопол. 14-16 Септември 1999), ТУ - София, България 1999, с.110-114.
- [2] Семерджиев А., Автоматизация на контрола в машиностроенето, С.Техника 1990
- [3] Семерджиев А., Тодоров Д., Ръководство за лабораторни упражнения по устройства за автоматичен контрол, София, Техника 1977
- [4] Digital Pressure Sensor SMC PSE 300, , SMC Corporation, PDF Version 2009.
- [5] <http://ibr.com/>.