

PAPER • OPEN ACCESS

Graph-analytic approach to determine the position of the initial impact in the event of pedestrian accidents

To cite this article: Milena Savova-Mratsenkova and Georgi Palagachev 2020 *IOP Conf. Ser.: Mater. Sci. Eng.* **878** 012042

View the [article online](#) for updates and enhancements.

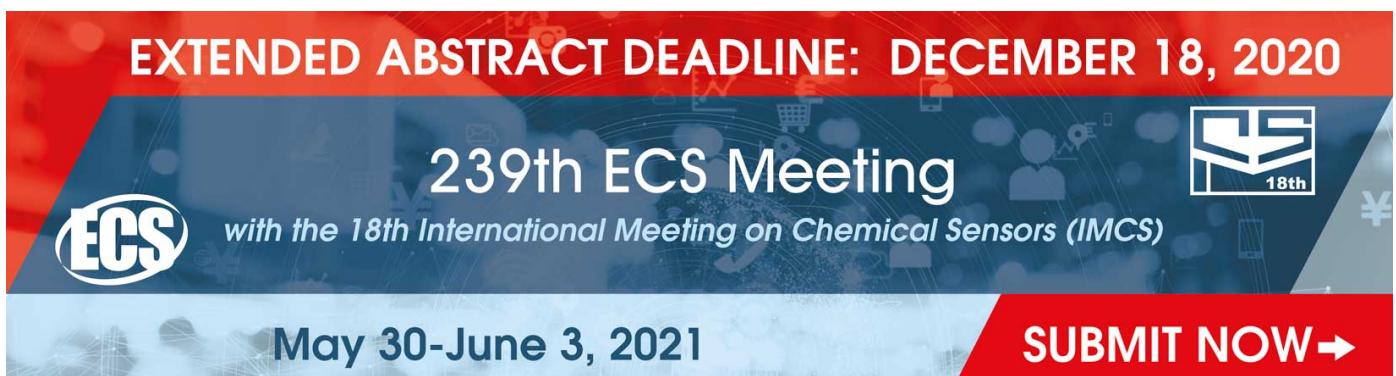

EXTENDED ABSTRACT DEADLINE: DECEMBER 18, 2020

239th ECS Meeting
with the 18th International Meeting on Chemical Sensors (IMCS)

May 30-June 3, 2021

SUBMIT NOW →

The banner features a red top section with white text, a blue middle section with white text and logos, and a red bottom section with white text. The background of the blue section contains faint icons related to science and technology.

Graph-analytic approach to determine the position of the initial impact in the event of pedestrian accidents

Milena Savova-Mratsenkova¹ and Georgi Palagachev¹

¹Technical University of Sofia, Faculty of Transport, Department of Combustion Engines, Automobile Engineering and Transport, Bulgaria

savova@tu-sofia.bg

Abstract: In the present research the authors propose a graph-analytic approach to determine the position of the initial impact in the event of pedestrian accidents. When investigating the velocity of movement of the vehicle (participating in the accident), mechanics theorems and parameters are used, which are reported in a scheme and are consistent with the data, gathered from the scene of the accident. The present study uses case law data from a real road traffic accident. The proposed approach can find wide application in the practice of pedestrian accident reconstruction in the absence of specific data that uniquely identify the exact location in the lane in which the initial impact between the vehicle and the pedestrian had happened.

1. Introduction

The vast automobilization in the recent years meets the ever-growing need of the society of vehicles, but it also causes a number of negative consequences, affecting traffic safety. This demands systematic research and analysing the main causes of road traffic accidents. The choice of means to limit the causes of road traffic accidents is necessarily based on extensive research and analysis. An essential step is selecting the right approach to recreate the mechanism of the road traffic accident, which is based on research, analysis and drawing conclusions, we take them into account to determine the causes and events that led to their occurrence [1, 2, 3]. Determining the objective circumstances for the occurrence of road accidents is a key element in establishing the culpability of participants and, accordingly, on a more global scale, to take appropriate preventive measures so as to improve road safety in the future.

In the current research, object of study are accidents involving pedestrians. Most of them occur in settlements and the main pedestrian groups in risk are children under 14 and elderly people [6]. Expert analysis in this group of road traffic accidents is carried out according to certain methodologies, tailored to the specific conditions of the accident [1, 5, 6, 9, 10, 11]. The pedestrian may be injured as a result of the initial impact with the vehicle or during a subsequent collision with the front cover, the front window, the front column, the front part of the ceiling, the fall on the ground, the subsequent overtaking by the vehicle itself or another vehicle. Familiarity with traumatism is required to describe the complete physical process from initial contact to the fall of the victim on the road surface [6,7, 8].

2. Exhibition:

When conducting an expert analysis of a road traffic accident, based on the data provided from the pre-trial proceedings, the mechanism of the investigated incident is restored by assessing the particular road situation and the actions of the individual road users [1, 5, 8]. For this purpose, it is necessary to



determine the location of the individual participants at the time of the initial impact, their position relative to the lane, their initial velocity and their velocity at the moment of impact. The key to ensuring accuracy of the analysis is correct determination of the place of initial contact between the participants by fixing it with two coordinates - longitudinally and transversely to the lane. Defining it accurately is essential to carry out the subsequent expert analysis and to adequately address the legal case regarding the technical feasibility of preventing a road accident.

The main output data, while determining the location of the initial impact are the documents, gathered during the investigation: incident inspection control, photographic materials, conclusion of forensic expertise, protocol for conducted investigative experiment, the protocols from the interrogation of the driver, the victim and the witnesses. In determining the location of impact, it is necessary to take into account the trajectory of movement of the vehicle and the position of the detected deformations on it.

Case-law data from a real road traffic accident were used to present the graph-analytic approach developed by the authors in determining the place of initial contact in a pedestrian accident.

The investigated road traffic accident occurred during daylight hours, with good visibility between bus brand "Iveco" model "Mago" and a pedestrian. The roadway in the area of the road traffic accident was open to traffic in both directions with one lane in each direction. The pavement was smooth with clean asphalt. The road section where the traffic accident occurred is straight, no incline. The width of the roadway is 7.50 m, the two lanes are separated by a continuous dividing line – type M1, which near the turnout on the left at RP1, turns into a broken dividing line – type M3. The lane in which the bus was moving is 3.50 m wide, and the lane in the opposite direction is 4.00 m wide. To the right of the right boundary line there is asphalt banquet with unformed edges and a width of 3.75 m. To the left of the left boundary line there is a 2.30 m wide pavement and a curb. There are no walkways in the accident area.

The participants in the investigated road traffic accident are:

- Iveco bus, Mago model, with the following technical characteristics: overall dimensions (l x b) 7,555 x 1,950 m; longitudinal base 4,250 m; width of front track 1,900 m; front overhang 1,20 m; front tires with size 205/75 R16; rear tire size 225/75 R16; own table 4200 kg; maximum mass 6500 kg. During the inspection by the investigating authorities, after the road traffic accident, the following damage was ascertained on the bus: lateral cracks on the lower right side of the front bumper with broken pieces of paint measuring 1 x 2 cm, the first crack being at a height of 0.25 m, the second at 0.37 m and the third at 0.42 m. All are from the front bumper length from 0.30 m to 0.40 m. Exactly, at the right corner of the bumper, at altitudes from 0.48 m to 1.10 m, a layer of old scratches was detected;

- The victim – a 83-year-old pedestrian at the time of the road traffic accident.

During the inspection by the investigating authorities of the accident, the direction of the inspection was chosen to be the direction of the Iveco bus, the landmark was chosen to be a concrete lighting pole, standing on the left walkway in the direction of the inspection and for baseline was used the imaginary line that goes through the landmark perpendicular to the roadway. The following measurements were made relative to this line: in the right lane, in the direction of the bus, two traces of tires are found with trace width - 0.42 m, it starts at a distance of 6.70 m before RP1 and 1 m to the right of the dividing line. The trace ends longitudinally at a distance of 7.20 m after RP1 and 0.62 m to the right of the dividing line. The total length of the trace is 13.90 m. The width of each trace is 0.17 m; rear left outside tire of bus Iveco is found outside the roadway, 0.55 m from the boundary line and 6.41 m from RP1; the front left tire of bus Iveco is found outside of the roadway, 0.55 m to the left of the boundary line and 10.65 m from RP1; just before the Iveco bus a blood stain was found and documented in the attached photo material. During the inspection, the bus was oriented with its front in the direction of its original movement. To the inspection protocol photo material is attached.

Based on the data from the inspection protocol a detailed scale scheme of the road traffic accident was drawn up (figure 1).

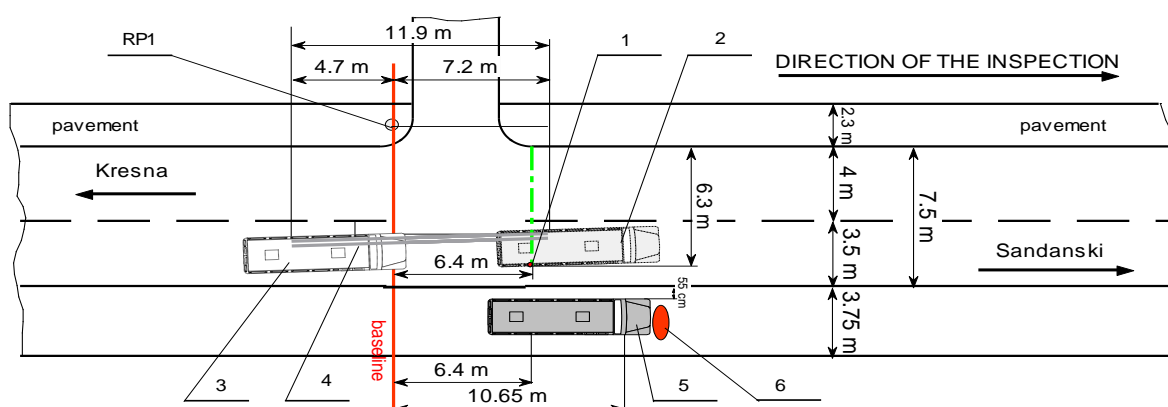
**KEY:**

1. Position of the bus at the end of the brake traces;
2. Position of the bus at the beginning of the brake traces;
3. Brake traces;
4. Position of the bus, described in the inspection protocol;
5. Blood stain;
6. Reference point – RP1

Figure 1. Scale diagram of the accident.

In order to restore the mechanism of the investigated road traffic accident, it is necessary to determine the location of the impact and the velocity of the bus at the initial moment and at the moment of impact [1, 5]:

- The velocity of the bus at the initial moment in which the driver reacted to the hazardous situation can be calculated technically using the length of the brake trace, described in the inspection of the accident left by the rear left wheels and is 13.90 m long. For this purpose, the following formula is used:

$$V_{Iveco-0.} = 0.5 \cdot j \cdot t_H + \sqrt{2 \cdot S_S \cdot j}, \quad (1)$$

where: $V_{Iveco-0.}$ - the initial velocity of the Iveco bus;

$\mu = 0,6$ - coefficient of adhesion;

$j = 1,2 \cdot \mu \cdot g = 7,06 \text{ m/s}^2$ - maximum braking delay according to the specific conditions for a bus equipped with ABS;

$t_H = 0,8 \text{ s}$ – time for increasement of the brake delay of a bus in a loaded condition;

$S_S = 13,90 \text{ m}$ – length of the brake trace.

$$V_{Iveco-0.} = 0,5 \cdot 0,8 \cdot 7,06 + \sqrt{2 \cdot 7,06 \cdot 13,90} = 16,83 \text{ m/s} = 60,60 \text{ km/h} \quad (2)$$

The velocity of movement of the Iveco bus in the moment, in which the driver actuated the brake system, was approximately 60,60 km/h.

- The velocity of movement of the bus in the moment of the impact can be defined with the help of different analytical methods. In this particular case two of them have been used.

Method 1 (Appel) – the velocity of movement of the bus in the moment of the impact is defined by the distance in which the pedestrian's body is thrown.

$$V_{Iveco-y} = \sqrt{\frac{S_r}{0,070}}, \text{ m/s} \quad (3)$$

where $V_{Iveco-y}$ is the velocity of the bus at the moment of the impact, m/s;

S_{τ} - the distance in which the pedestrian's body is thrown, m.

Method 2 – the velocity of movement of the bus in the moment of the impact is defined by the brake traces after the impact. The following formula is used:

$$V_{Iveco-y} = \sqrt{2 \cdot S_y \cdot j}, \text{ m/s} \quad (4)$$

S_y - distance travelled from the point of impact till the bus finally stopped;

The velocity of the bus Iveco in the moment of the impact is defined by using the two methods and a scheme (shown in figure 1). The results from the conducted analysis are presented in table 1.

Table 1. Results from the conducted analysis.

№	S_{τ} m	S_y m	j m/s ²	$V_{Iveco-y}$ m/s (Appel)	$V_{Iveco-y}$ m/s (Brake traces)	$V_{Iveco-y}$ km/h (Appel)	$V_{Iveco-y}$ km/h (Brake traces)	Δ km/h
1	5,97	5	7,06	9.235026	8.402381	33.25	30.25	3
2	6,36	5,5	7,06	9.531901	8.812491	34.31	31.72	2.59
3	6,81	6	7,06	9.863352	9.204347	35.51	33.14	2.37
4	7,26	6,5	7,06	10.18402	9.580188	36.66	34.49	2.17
5	7,73	7	7,06	10.5085	9.941831	37.83	35.79	2.04
6	8,17	7,5	7,06	10.80344	10.29077	38.89	37.05	1.85
7	8,59	8	7,06	11.07765	10.62826	39.88	38.26	1.62
8	9.1	8.5	7,06	11.40175	10.95536	41.05	39.44	1.61
9	9.56	9	7,06	11.68638	11.27298	42.07	40.58	1.49
10	10.03	9.5	7,06	11.9702	11.58188	43.09	41.69	1.4
11	10.49	10	7,06	12.24162	11.88276	44.07	42.78	1.29
12	10.97	10.5	7,06	12.51856	12.17621	45.07	43.83	1.23
13	11.45	11	7,06	12.7895	12.46274	46.04	44.87	1.18
14	11.95	11.5	7,06	13.06577	12.74284	47.04	45.87	1.16
15	12.34	11.9	7,06	13.27726	12.96256	47.8	46.67	1.13
16	12.44	12	7,06	13.33095	13.01691	47.99	46.86	1.13
17	12.8	12.5	7,06	13.52247	13.28533	48.68	47.83	0.85
18	13.4	13	7,06	13.83577	13.54843	49.81	48.77	1.03
19	13.98	13.5	7,06	14.13203	13.80652	50.88	49.7	1.17
20	14.56	14	7,06	14.42221	14.05987	51.92	50.62	1.3

The values of the velocity at the moment of the accident, estimated with the help of the two aforementioned methods, are closest to each other when the distance at which the pedestrian's body is thrown is $S_{\tau} = 12,80$ m and the length of the brake traces left after the accident is $S_y = 12,50$ m.

Therefore, the velocity of the bus at the moment of the traffic accident is estimated to be approximately $V_{Iveco-y} = 48,26$ km/h.

The place of the collision is determined when the evidence found and described in the written report from the scene of the accident are taken into account: length and location of the brake trace, deformations in the front part of the bus and location of the blood stain.

Considering the established velocity at the moment of the accident it is determined that the scene of the accident is located along the roadway in the right traffic lane (the lane in which the bus was traveling), at a distance of 0,20 m before the accepted baseline, going perpendicular through RP 1 (figure 2) and along the width of the roadway at around 6,70 m to the right of the left end of the roadway.

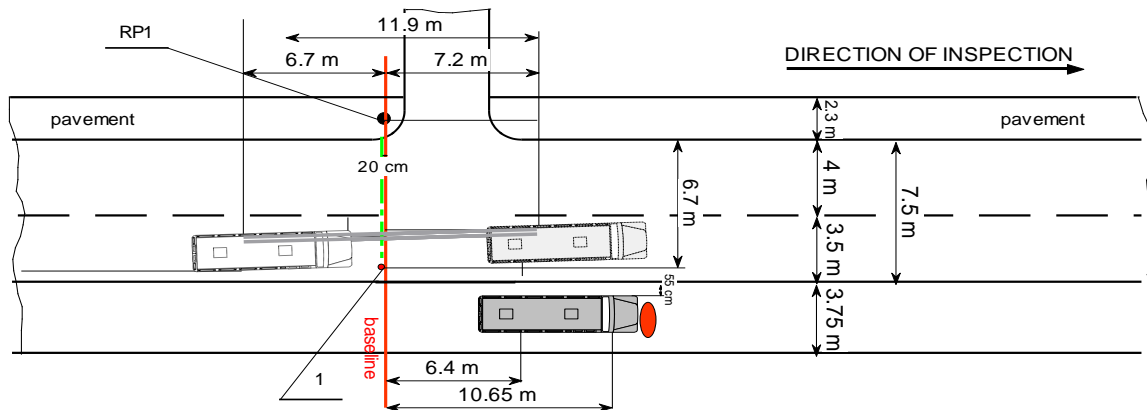

KEY:

1. Place of the initial contact;
2. - - - - - Pedestrian movement trajectory.

Figure 2. Scheme of the accident, indicating the location of the impact.

3. Conclusion

Every road traffic accident is characterized with its own specifics, which implies the need of choosing an adequate approach when conducting an expert analysis. The current scientific article proposes a graph-analytic approach for determining the place of the initial impact when analysing road traffic accidents with a pedestrian. In the present research case-law data from a real traffic accident were used. When investigating the velocity of motion of the vehicle that participated in the accident two methods with wide application in the expert practice have been used. The suggested approach can successfully help for the reconstruction of road traffic accidents with pedestrians in situations where there is no specific data in order for the exact place of the initial collision between the vehicle and the pedestrian to be determined.

Acknowledgements

The author/s would like to thank the Research and Development Sector at the Technical University of Sofia for the financial support.

References

- [1] St. Karapetkov, Auto-technical expertise. Sofia, Technical University, 2005
- [2] M. Savova-Mratsenkova, Djonev G., Influence of the angle of the directory on the accuracy of the measurement when determining vehicles' velocities in case of an impact between them. Conference BulTrans, Sozopol, 11-13 September 2017.
- [3] G.Djonev, Savova-Mratsenkova M., Methods for determining the velocity of vehicles in case of an impact between them. Conference BulTrans, Sozopol, 11-13 September 2017.
- [4] A. Pisarev, and others. Course in Theoretical Mechanics - Part II. Sofia, Technika, 1988.L.A. Klein, M.K. Mills, D.P. Gibson, in: Traffic Detector Handbook, vol. I, third ed., Turner-Fairbank Highway Research Center, McLean, VA, 2006.
- [5] V. Ilarionov, Examination of an accident. Moscow, „Transport“, (1989).
- [6] L.Petrescu, Petrescu Al., Vehicle-pedestrian collisions - Aspects regarding pedestrian kinematics, dynamics and biomechanics, CAR-2017 IOP Publishing: Materials Science and Engineering

- 252 (2017).
- [7] Fang Wang, Chao Yu, Guibing Li, Yong Han, Bingyu Wang, Jikuang Yang, Diandian Lan, A Study on Influence of Minivan Front-End Design and Impact Velocity on Pedestrian Thorax *Kinematics and Injury Risk, Applied Bionics and Biomechanics* Volume **2018**, Article ID 7350159, 8 pages
 - [8] L. Levulyte et al, Pedestrians' Role in Road Accidents, DOI: [http://dx.doi.org/10.7708/ijtpe.2017.7\(3\).04](http://dx.doi.org/10.7708/ijtpe.2017.7(3).04).
 - [9] World Health Organization. Global status report on road safety 2015/ <http://www.who.int>
 - [10] The State-Public Consultative Commission on the Problems of Road Safety. Statistical road safety data / <http://dokkpbdp.mvr.bg/default.htm/>
 - [11] National Road Safety Improvement Strategy of the Republic of Bulgaria 2011-2020.