

SOFIA, 2014

VOLUME 8

ISSN 1314-0078

ANNUAL JOURNAL
OF
ELECTRONICS

Technical University of Sofia

**Faculty of Electronic
Engineering and Technologies**

Sponsored by:



Technical University of Sofia

project 141ДН0014-03



Faculty of Electronic
Engineering and Technologies



SOFIA, 2014

VOLUME 8

ISSN 1314-0078

ANNUAL JOURNAL
OF
ELECTRONICS



Technical University of Sofia



**Faculty of Electronic
Engineering and Technologies**

ANNUAL JOURNAL OF ELECTRONICS

EDITOR'S BOARD

President:	Prof. Dr. Ratcho Ivanov
Vice President:	Prof. Dr. Marin Hristov
Members:	Prof. DSc. Georgy Mihov
	Prof. Dr. Stefan Ovcharov
	Assoc. Prof. Dr. Peter Yakimov

LIST OF REVIEWERS

Angel Popov , Technical University of Sofia, Bulgaria	Ivailo Zhivkov , Bulgarian Academy of Sciences, Bulgaria
Anna Andonova , Technical University of Sofia, Bulgaria	Ivo Iliev , Technical University of Sofia, Bulgaria
Dimitar Todorov , Technical University of Sofia, Bulgaria	Krassimir Denishev , Technical University of Sofia, Bulgaria
Dimitar Arnaudov , Technical University of Sofia, Bulgaria	Marin Marinov , Technical University of Sofia, Bulgaria
Elissaveta Gadjeva , Technical University of Sofia, Bulgaria	Mityo Mitev , Technical University of Sofia, Bulgaria
Emil Dimitrov , Technical University of Sofia, Bulgaria	Nikolay Hinov , Technical University of Sofia, Bulgaria
Emil Manolov , Technical University of Sofia, Bulgaria	Peter Goranov , Technical University of Sofia, Bulgaria
Galidia Petrova , Technical University of Sofia, Bulgaria	Ratcho Ivanov , Technical University of Sofia, Bulgaria
Georgi Nikolov , Technical University of Sofia, Bulgaria	Rossen Radonov , Technical University of Sofia, Bulgaria
Georgy Mihov , Technical University of Sofia, Bulgaria	Stoyan Nihtyanov , TU-Delft, the Netherlands
Grisha Spasov , Technical University of Sofia, Bulgaria	Todor Djamiykov , Technical University of Sofia, Bulgaria
Irena Jekova , Bulgarian Academy of Sciences, Bulgaria	Todor Stefanov , Leiden University, the Netherlands
Ivailo Pandiev , Technical University of Sofia, Bulgaria	Tsvetana Grigorova , Technical University of Sofia, Bulgaria

The Journal is issued by the FACULTY OF ELECTRONIC ENGINEERING AND TECHNOLOGIES, TECHNICAL UNIVERSITY OF SOFIA, BULGARIA.

The Journal includes the selected papers from the International Scientific Conference Electronics'14, held on 11-13 September 2014 in Sozopol, Science Days of Technical University of Sofia, Bulgaria.

Sponsored by:

TU – SOFIA, project 141ДН0014-03
Faculty of Electronic Engineering and Technologies, TU – Sofia
IEEE Bulgaria Section
IEEE ED/CPMT/MTT/AP Chapter Sofia
IEEE CAS/SSCS Chapter Sofia

CONTENTS

Wintner, E., H. Kofler, A. Agarwal, M. Deneva, M. Nenchev, Laser Ignition of Engines – A Contribution to Environmental Protection and a Challenge to Laser Technology	1
Deneva, M., M. Nenchev, E. Wintner, S. Topsu, Two-Line High-Power Single Active Element Nd:YAG Quantum Electronics Generator with Coaxial Architecture-Optimization	9
Djamiykov, T., Sun Altitude Sensor	13
Kim, N., A. Andonova, Computationally Efficient Methods for Decision Feedback Algorithms based on Minimum Error Entropy	17
Bozhikova, V., M. Stoeva, Search-based Approach for Software Cost Estimation	20
Rao, P., S. Milosavljevic, U. Kroth, Ch. Laubis, St. Nihtianov, High Efficiency UV Photodiodes Fabricated on p-type Substrate	24
Mohammadi, V., S. Mohammadi, S. Ramesh, St. Nihtianov, Numerical Gas Flow and Heat Transfer Simulation in the ASM Epsilon 2000 CVD Reactor for Pure Boron Deposition	28
Delibozov, N., R. Radonov, M. Hristov, Design and Fabrication of "Matrix" MEMS Device	32
Gieva, E., M. Todorov, T. Takov, B. Nikolova, Integrated Sensors' Modelling via Different Circuit Simulators	36
Spasov, G., Method for Auger Analyses of Thick Insulators Samples	40
Aleksandrova, M., Sv. Andreev, I. Ruskova, G. Dobrikov, Flexible Thick Film Electroluminescent Devices: Influence of the Mechanical Stress on Layers Behavior	43
Vucheva, Y., G. Kolev, M. Aleksandrova, K. Denishev, Influence of the Polarization on Some Dielectric Parameters of Thin PVDF Layers	47
Hallez, H., P. Alcalá, J. Boydens, Fall Detection Using Multi-sensory Accelerometer Sensor Network	51
Shoshkov, Ts., G. Mihov, Real-Time Subtraction Procedure for Power-Line Interference Removing from ECG: High Level Synthesis with Compaan	54
Dobrev, D., T. Neycheva, Software PLL for Power-line Interference Synchronization: Design, Modeling and Simulation	58
Dobrev, D., T. Neycheva, Current Driven Automatic Electrode Impedance Balance for Ground-free Biosignal Acquisition	62
Feradov, F., T. Ganchev, Detection of Negative Emotional States from Electroencephalographic (EEG) Signals	66
Jekova, I., V. Krasteva, Al. Kalaydjiev, Ts. Mudrov, S. Ménétré, J.-Ph. Didon, Respiration Detection Implemented in Multichannel ECG Front End Module: A Preliminary Study	70
Tabakov, S., Real Time Detecting of Pacemaker Artifacts	74

Tsibulko, V., I. Iliev, I. Jekova, Methods for Detecting Pacemaker Pulses in ECG Signal: A Review	77
Tsibulko, V., Features and Application of ADAS1000/ADAS1000-1/ADAS1000-2 Low Power-Five Electrode ECG System	81
Spasova, V., Experimental Evaluation of Keypoints Detector and Descriptor Algorithms for Indoors Person Localization	85
Shopov, M., G. Petrova, G. Spasov, Prototype of a Medical Gateway for Personal Healthcare Systems - Design and Implementation	88
Petrova, G., Patient Data Integration in Electronic Health Record Systems	92
Grigorova, Ts., K. Asparuhova, Unified Method for Behavioral Modeling of IGBT	96
Manolov, E., CMOS High-Swing Current Mirror Sizing: A Case Study	100
Kovacheva, M., E. Stoimenov, I. Pandiev, FPGA – based Arbitrary Integer Frequency Divider with 50% Duty Cycle of the Output Signal	104
Stoimenov, E., I. Pandiev, M. Kovacheva, Modeling and Implementation of FPGA – Based Flexible Voltage-to-Frequency Converter	108
Manoilov, P., Design and Investigation of a Multi-Core System on Chip	112
Gadjeva, E., Development of Computer-Aided Approach to Parameter Extraction of Spiral Inductor Model	116
Yordanov, R., I. Ucherdzhiev, I. Yordanova, Automated System for Visual Control in Microelectronics	120
Genoff, J., Floating Gate EPROM Instability for True Randomness Generation	124
Ribov, B., Multipath Effects in High Speed Digital Radio Communications	128
Jordanova, L., L. Laskov, D. Dobrev, Investigation on DVB-S2 Channel Characteristics	132
Valkov, K., I. Dochev, Overview of Electromagnetic Interference Impact over Wireless Systems for Control and Data Acquisition Working on 2.4 GHz ISM Band	136
Shehova, D., P. Yakimov, Teaching PLL Fundamentals Using MATLAB/Simulink	139
Shehova, D., P. Yakimov, Sl. Lyubomirov, A. Chekichev, Active Filters Design Teaching Using FilterPro™ Software	143
Goranova, M., Y. Danchev, L. Stoyanova, Automatic Student Assessment in C# .NET Windows Forms/Console Applications	146
Stefanova, S., T. Vasileva, Trialogical Approach to Knowledge Practices in CAD Education	150
Vasileva, T., V. Tchoumatchenko, S. Stefanova, KNORK Project Objectives	154
Vasileva, T., V. Tchoumatchenko, Promoting Knowledge Practices in Electronic Education	158
Stoeva, M., V. Bozhikova, Hierarchical Model for Storage and Retrieval of Images Content-Based Systems	162
Minkov, D., H. Yamada, Main Characteristics of the Tabletop Synchrotron Light Sources MIRRORCLE	166
Djermanova, N., J. Kiss'ovski, V. Vatchkov, Portable Arduino – Based LCR – Meter	170

Yordanov, R., R. Miletiev, E. Iontchev, I. Simeonov, Study of Asynchronous Mode of Quad Sensor Structure	174
Hensel, St., M. Marinov, Time Signal Based Warping Algorithms for Low Speed Velocity Estimation of Rail Vehicles	177
Nikolov, G., Extending Capability of Modular Source – Measure Units using Virtual Technique	181
Georgiev, P., I. Zhivkov, M. Vala, D. Todorov, R. Yordanov, M. Weiter, Wide Range Current Amplifier with Data Acquisition System	185
Kokolanski, Z., Cv. Gavrovski, Vl. Dimcev, Simple Sensor-to-Personal Computer Interface by Using Virtual Instrumentation	189
Cordemans, P., E. Thyebaut, D. Pissort, J. Boydens, Embedded Software Resilience	192
Badarov, D., G. Mihov, Multifunctional Analyzer for Audio Signals Based on Xilinx FPGA	196
Bogdanov, L., R. Ivanov, Reducing Energy Consumption in Asynchronous and Synchronous Data Transfers	200
Krastev, K., Ts. Gotsov, A. Manukova-Marinova, Embedded System for Measurements and Data Acquisition with Web Interface Based on ARM Processors	204
Andreev, A., Embedded Management of Electronic Health Records	208
Astardzhiev, B., S. Ivanov, A Method for Provisioning a Twisted Pair Cable's Integrity Based on a Reflected Waveform Analysis of an Emitted Pulse	212
Dimitrov, Vl., P. Goranov, Analysis of a synchronous DC-DC converter working between two voltage sources	215
Kunov, G., E. Gadjeva, M. Petkova, T. Brusev, Stability Investigation using SPICE of BUCK DC-DC Converter	219
Nedialkov, I., D. Arnaudov, N. Hinov, Stand for Testing of Bi – Directional Converters in Photovoltaic Systems	223
Stoyanov, R., E. Rosenov, A. Marinov, V. Valchev, Modelling, Simulations and Design Considerations for Inrush Current Limiting Topologies	227
Marinov, A., E. Rosenov, R. Stoyanov, Modeling and Simulation of an Improved Microcontroller Based Desaturation Current Protection	231
Madankov, Y., Al. Vuchev, N. Bankov, Dynamic PSpice Model of CO ₂ Laser Tube	235
Spirov, D., N. Komitov, Three-Phase Soft-Switched Quasi Resonant DC Link Inverter for AC Motor Drives with Different Clamps	239

Stability Investigation using SPICE of BUCK DC-DC Converter

Georgi Tzvetanov Kunov, Elissaveta Dimitrova Gadjeva, Maria Petkova Petkova and Tihomir Sachev Brusev

Abstract – A stability investigation of the BUCK DC-DC converter with Average Current Mode Control is considered in the present paper. A Spice stability investigation equivalent circuit is composed. Using parametric analysis, zeros and poles of the current regulator transfer function are investigated. The optimal values of the compensation network elements for the current regulator are obtained. The stability of the converter operation is validated by Nyquist plot and transient analysis.

Keywords – Power Electronics, BUCK DC-DC Converters, Average Current Mode Control, Stability, Spice Simulation

I. INTRODUCTION

The basic methods of control used in the BUCK DC-DC converters are voltage mode control (VMC), peak current mode control (CMC) and average current mode control (ACMC). Their advantages and disadvantages are systematically summarized in [1,2,3]:

Voltage Mode Control:

The advantages are: stable modulation – less sensitive to noise, single feedback path, it can work over a wide range of duty cycles. The disadvantages are: loop gain proportional to V_{in} , LC double pole often drives type PID compensation, continuous current mode (CCM) and discontinuous current mode (DCM) differences – a compensation challenge, slow response to input voltage changes, current limiting must be done separately.

Current Mode Control:

The advantages are: power plant gain offers a single-pole roll-off, line rejection, cycle-by-cycle current limiting protection, current sharing. The disadvantages are: noise, minimum on-time, current probe (Rsense, current transformers).

Peak versus Average Current Mode Control:

The disadvantages of Peak CMC are: poor noise immunity (at switching on), slope compensation required

G. Kunov is with the Department of Power Electronics, Faculty of Electronic Engineering and Technologies, Technical University of Sofia, 8 Kliment Ohridski blvd., 1000 Sofia, Bulgaria, e-mail: gkunov@tu-sofia.bg

E. Gadjeva is with the Department of Electronics and Electronics Technologies, Faculty of Electronic Engineering and Technologies, Technical University of Sofia, 8 Kliment Ohridski blvd., 1000 Sofia, Bulgaria, e-mail: egadjeva@tu-sofia.bg

M. Petkova is with the Department of Power Electronics, Faculty of Electronic Engineering and Technologies, Technical University of Sofia, 8 Kliment Ohridski blvd., 1000 Sofia, Bulgaria, e-mail: mariya_petkova@tu-sofia.bg

T. Brusev is with the Department of Technology and Management of Communication Systems, Technical University of Sofia, 8 Kliment Ohridski blvd., 1000 Sofia, Bulgaria, e-mail: brusev@ecad.tu-sofia.bg

when $D > 0.5$, peak to average current error, topology problem when inductor current is other than output current. The advantages of ACMC are: average current tracks well the current program in CCM or DCM, noise immunity is excellent even at low set point, ACMC is working whatever the topology, slope compensation is not required but loop gain at F_{sw} is limited to achieve stability.

In the present paper the stability of work of BUCK DC-DC converter with Average Current Mode Control is investigated. It is performed using the program Cadence PSpice. The simplified circuit of the converter is shown in Fig. 1.

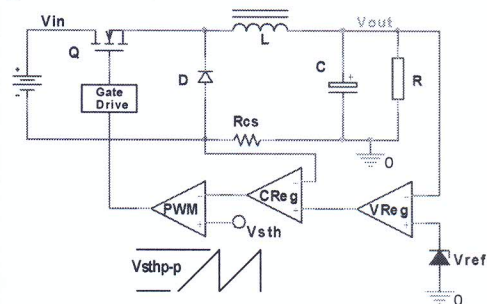

Fig.1. Simplified circuit of BUCK DC-DC with ACMC

In the classical theory of automated control, a closed loop system is represented by its mathematical description [4]. This approach, applied to BUCK DC-DC converter with ACMC, is illustrated in Fig. 2.

The designations for the separate blocks are: W_{Mod} – transfer function of the BUCK DC-DC converter, W_{LCR} – transfer function of the output filter, W_{CR} – transfer function of the current regulator (a PI regulator is used), W_{VR} – transfer function of the voltage regulator (a PID regulator is used). Applying the rules for the equivalent transformations, (Fig.2a, Fig.2b and Fig.2c), the system is reduced to a single block with equivalent transfer function W_e .

The mathematical description of the transfer functions of the separate blocks is shown as follows [5,6]:

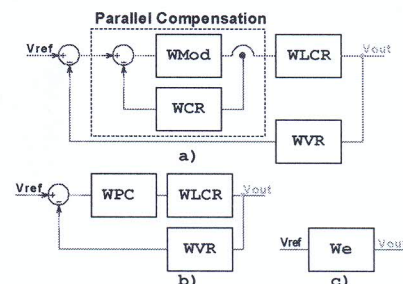

Fig.2. Equivalent transformations of the system

The transfer function of the Modulator:

$$W_{Mod}(s) = \frac{V_{in}}{V_{shp-p}} \quad (1)$$

The transfer function of the output filter:

$$W_{LCR} = \frac{1+sR_C C}{1+s(R_L+R_C)C+s^2 LC} \quad (2)$$

where:

R_L – direct-current resistance (DCR) of the filter inductor,
 R_C – electrical series resistance (ESR) of the filter capacitor.

The transfer function of the PI current regulator:

$$W_{CR}(s) = \frac{1}{R_{C1} \cdot C_{C1}} \cdot \frac{s + \frac{1}{R_{C2} \cdot C_{C2}}}{s \cdot \left(s + \frac{C_{C1} + C_{C2}}{R_{C2} \cdot C_{C1} \cdot C_{C2}} \right)} \quad (3)$$

The transfer function of the PID voltage regulator:

$$W_{VR}(s) = \frac{R_{V1} + R_{V3}}{R_{V1} R_{V3} C_{V1}} \cdot \frac{\left(s + \frac{1}{R_{V2} C_{V2}} \right) \left(s + \frac{1}{(R_{V1} + R_{V3}) C_{V3}} \right)}{s \left(s + \frac{C_{V1} + C_{V2}}{R_{V2} C_{V1} C_{V2}} \right) \left(s + \frac{1}{R_{V3} C_{V3}} \right)} \quad (4)$$

The transfer function of the Parallel Compensation:

$$W_{PC}(s) = \frac{W_{Mod}(s)}{1 + W_{Mod}(s) \cdot W_{CR}(s)} \quad (5)$$

The equivalent transfer function:

$$W_e(s) = \frac{W_{Mod}(s) W_{LCR}(s)}{1 + W_{PC}(s) W_{LCR}(s) W_{VR}(s)} = \frac{W_{Mod}(s) W_{LCR}(s)}{1 + s W_{Mod}(s) + W_{Mod}(s) W_{LCR}(s) W_{VR}(s)} \quad (6)$$

In [7], the mathematical description of the transfer functions of the output filter and the regulators is replaced by their real circuits. This approach, combined with the SPICE simulation, simplifies the stability investigation of the system. It is applied in the present paper.

II. STABILITY INVESTIGATION OF BUCK DC-DC CONVERTER

A. Calculation of the LC filter parameters

In order to perform stability investigation of the BUCK DC-DC regulator system, it is necessary to have the parameters of the mode in which it will work. The mode of operation includes the following parameters [6]:

- switching frequency: $F_{sw}=250$ kHz;
- input voltage: $V_{in}=15$ V;
- output voltage: $V_{out} = 5$ V;
- maximum output current: $I_{load-max} = 5$ A;

- inductor current ripple: $\Delta I_L=0.5$ A;
- output voltage ripple: $\Delta V_{out} = 0.25$ V;
- maximum change in load current: $\Delta I_{Load-max}=4$ A.

First, the smoothing filter is designed by the following equations[6]:

$$L \geq \frac{V_{in} - V_{out}}{\Delta I_L} \cdot \frac{V_{out}}{V_{in}} \cdot \frac{1}{F_{sw}} = 26.6 \mu\text{H} \quad (7)$$

We choose $L=33\mu\text{H}$.

$$C \geq \frac{L \Delta I_{Load-max}^2}{2 V_{out} \Delta V_{out}} = 267 \mu\text{F}$$

We choose $C=330 \mu\text{F}$ with $ESR=25$ m Ω .

The calculated L and C values define the cutoff frequency:

$$F_{LC} = \frac{1}{2\pi\sqrt{LC}} = 1.5 \text{ kHz}$$

and ESR zero frequency:

$$F_{ESR} = \frac{1}{2\pi C \cdot ESR} = 19.3 \text{ kHz}$$

B. Compensator calculation of the PI current regulator

A PI type compensator as a current regulator is shown in Fig. 3a. The location of its zero crossover frequencies is shown in Fig. 3b. The recommended values are [6]:

$$F_{Z1}=0.75 \times F_{LC}=1.125 \text{ kHz and } F_{P2}=0.5 \times F_{sw}=125 \text{ kHz.}$$

The desired bandwidth of the system ($F_0=25$ kHz) is chosen bigger than F_{ESR} .

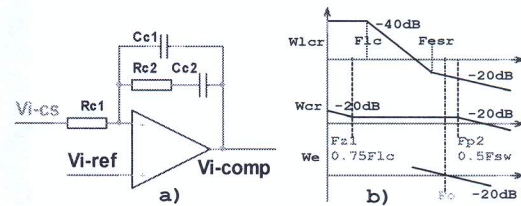

Fig.3. PI type compensator as a current regulator

The recommended parameter value [6] of the resistor R_{C1} is between 1 k Ω and 5 k Ω . It is chosen $R_{C1}=3.9$ k Ω .

The parameter value of the resistor R_{C2} is calculated by the equation:

$$R_{C2} = \frac{F_{ESR} F_0}{(F_{LC})^2} \cdot \frac{V_{shp-p}}{V_{in}} R_{C1} = 278 \text{ k}\Omega \quad (8)$$

We choose $R_{C2}=270$ k Ω .

The relationship between the parameter values of the passive components of the regulator and the poles of the compensator is given by equations [6]:

$$F_{z1} = \frac{1}{2\pi R_{C2} C_{C2}} \quad (9)$$

$$F_{P2} = \frac{1}{2\pi R_{C2} C_{C1}} \quad (10)$$

By the above equations standard values are calculated and chosen: $C_{C2}=4.7$ pF and $C_{C1}=680$ pF.

C. Compensator calculation of the PID voltage regulator

A PID type compensator as voltage regulator is shown in Fig. 4a. The location of its zero crossover frequencies is shown in Fig. 4b. The recommended values are [6]:

$$F_{Z1}=0.75 \times F_{LC}=1.125 \text{ kHz}; F_{Z2}=F_{LC}=1.5 \text{ kHz};$$

$$F_{P2}=F_{ESR}=19.3 \text{ kHz and } F_{P3}=0.5 \times F_{sw}=125 \text{ kHz.}$$

The desired bandwidth of the system ($F_0=15$ kHz) is chosen less than F_{ESR} .

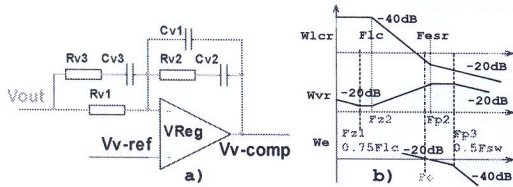

Fig.4. PID type compensator as a voltage regulator

The recommended parameter value of the resistor R_{r1} is between 1 kΩ and 5 kΩ. We choose $R_{r1}=3.9$ kΩ.

The parameter value of the resistor R_{r2} is calculated by the equation:

$$R_{r2} = \frac{F_0}{F_{LC}} \cdot \frac{V_{shp-p}}{V_m} R_{r1} = 13 \text{ k}\Omega \quad (11)$$

We choose $R_{r2}=13$ kΩ.

The relationship between the parameter values of the passive components of the regulator and the poles of the compensator is given by equations:

$$F_{Z1} = \frac{1}{2\pi R_{r1} C_{v1}} \quad (12)$$

$$F_{Z2} = \frac{1}{2\pi C_{v3} (R_{v1} + R_{v3})} \quad (13)$$

$$F_{P2} = \frac{1}{2\pi C_{v3} R_{v3}} \quad (14)$$

$$F_{P3} = \frac{1}{2\pi R_{r1} C_{r2}} \quad (15)$$

By the equations (11) to (15) standard value are calculated and chosen for $C_{r1}=100$ pF; $C_{r2}=10$ nF; $C_{v3}=27$ nF; $R_{r3}=47$ Ω.

D. Stability investigation equivalent circuit

The equivalent circuit for stability investigation is shown in Fig. 5. The Nyquist plot is shown in Fig. 6a with calculated parameters in correspondence with the conditions in Chapter II.A and II.B. It is seen that the system is unstable (Fig. 6a). Using Parametric Analysis

(Fig. 5), the values of the frequency F_{Z1} and F_{P2} are obtained, which ensure the system stability.

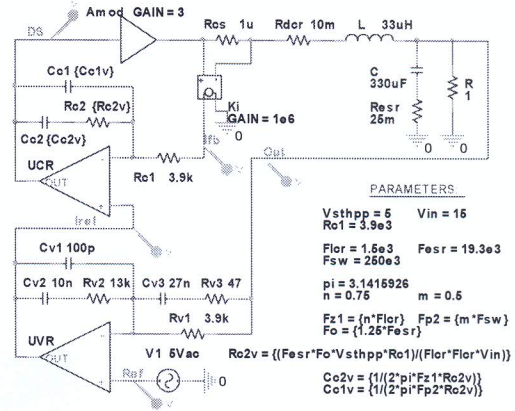
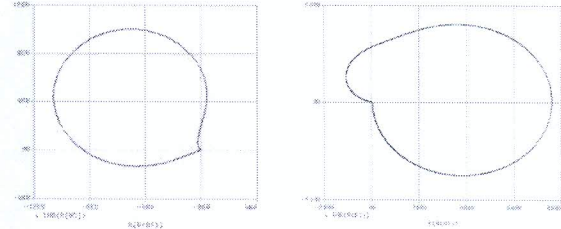

Fig. 5. Equivalent circuit for stability investigation

A recalculation of the capacitor values C_{C2} and C_{C1} is performed in the compensation network of the PI regulator and standard values are chosen: ($C_{C2}=390$ nF and $C_{C1}=2.7$ nF). It is seen from the Nyquist plot in Fig. 6b that the system is stable.



a) $F_{Z1}=0.75F_{LC}; F_{P1}=0.5F_{SW}$ b) $F_{Z1}=0.001F_{LC}; F_{P1}=0.001F_{SW}$

Fig.6. Nyquist plot of the system

E. Magnitude vs. frequency responses of the basic blocks of the converter

The Magnitude-vs. frequency responses of the building blocks of the BUCK DC-DC converter with Average Current Mode Control are obtained using the simulation circuit shown in Fig. 7.

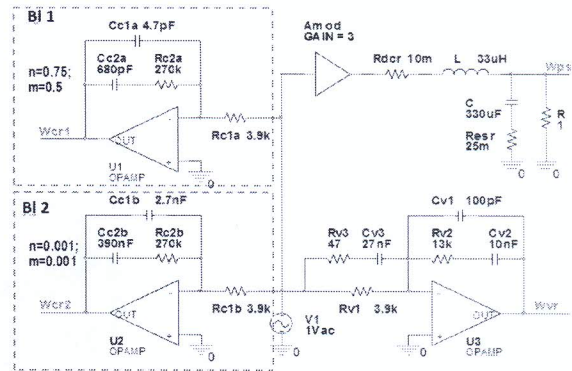

Fig.7. Simulation circuit for obtaining the magnitude-vs. frequency responses of the building blocks

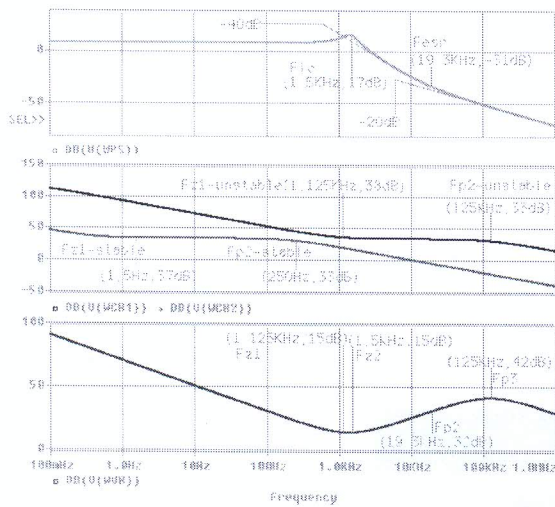

Fig. 8. Simulation results for the magnitude-vs. frequency responses

The circuit of the PI regulator, corresponding to unstable mode of operation, is simulated by $Bl_1(n=0.75$ and $m=0.5)$.

The circuit of the PI regulator, corresponding to stable mode of operation, is simulated by $Bl_2(n=0.001$ and $m=0.001)$.

The simulation results are shown in Fig. 8. It is seen that a stable mode of operation is achieved, placing the zero and the pole of the PI regulator (F_{z1} and F_{p2}) in the low frequency range.

III. TRANSIENT STABILITY INVESTIGATION OF BUCK DC-DC CONVERTER

The full electrical circuit of the BUCK DC-DC converter with Average Current Mode Control is shown in Fig. 9, using the obtained parameter values of the PI regulator, which ensure a stable mode of operation.

The simulation results in the time domain are shown in Fig. 10. The circuit is simulated for two stepping variations of the load current (from 1.5A to 5A and from 5A to 1.5A). The simulation results for the transient responses confirm the system stability.

IV. CONCLUSION

Stability of the BUCK DC-DC converter with Average Current Mode Control has been investigated. The optimal values of the compensation network elements for the current regulator are obtained corresponding to a stable system. A parametric analysis in the frequency domain using *Cadence PSpice* simulator is applied for this purpose. Stability investigation is performed using frequency criterion (*Nyquist* plot), as well as using simulation in the time domain. The obtained simulation results confirm the validity of the proposed procedure for optimal value determination of the compensation network elements for the current regulator.

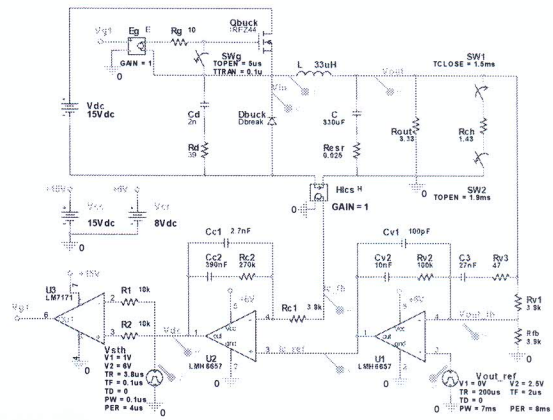

Fig. 9. The full electrical circuit of the BUCK DC-DC converter with Average CMC, corresponding to a stable mode of operation

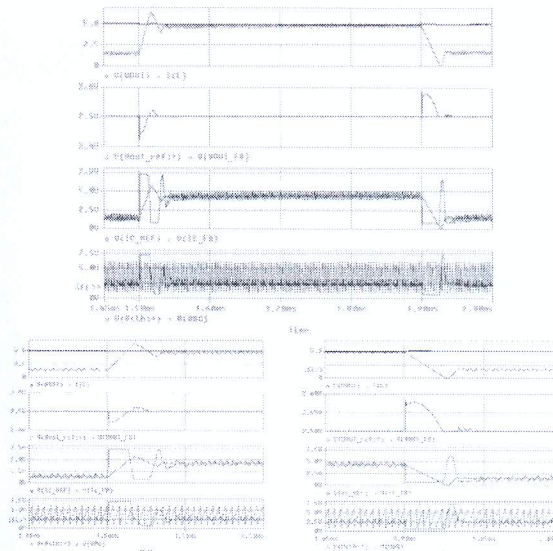

Fig.10. Simulation results in the time domain

REFERENCES

- [1] <http://www.montefiore.ulg.ac.be/~geuzaine/ELEC0055/>
- [2] P.Cooke. *Modeling average current control*, Proc. APEC, New Orleans, 2000, Vol.1, pp. 256-262
- [3] L. Dixon. *Average Current Mode Control of Switching Power Supplies*, www.ti.com/lit/an/slua079/slua079.pdf
- [4] K. Ishtev. *Theory of automatic control*, Technical University of Sofia, 2007.
- www.ti.com/lit/an/slva274a/slva274a.pdf
- [5] D. Mattingly. *Designing Stable Compensation Networks for Single Phase Voltage Mode Buck Regulators*, Intersil, Technical Brief, December 2003, TD 417.1 www.intersil.com/data/tb/tb417.pdf
- [6] A. M. Rahimi, P. Parto, P. Asadi. *Compensator Design Procedure for Buck Converter with Voltage-Mode Error-Amplifier*, *International Rectifier*, Application Note AN-1162 www.irf.com/technical-info/.../an-1162.pdf
- [7] R. Sheehan, *Understanding and Applying Current Mode Theory*, Power Electronics Technology Exhibition and Conference, October 30 – November 1, 2007, Dallas <http://www.ti.com/lit/an/snva555/snva555.pdf>