

Some Problems in Simulation Modelling of Terry Fabrics

Nikolay Nikolov, Diana Germanova-Krasteva

Technical University of Sofia

Sofia, Bulgaria

dianakra@tu-sofia.bg

Abstract—The aim is to analyze the problems arising in geometry modelling and simulating the deformation behaviour of pile structure fabrics, as well as to propose different approaches for solving them. The SolidWorks CAD system has been used for fabrics geometry modelling, while the ANSYS Workbench software product, using the finite elements method, has been used for the simulation of its deformation behaviour. A concept has been created and simulation models have been developed for terry fabrics in different stages of processing. The models obtained are highly accurate in terms of geometry, but need some refinement of parameters determining the deformation behaviour. An analysis of the influence of these parameters has been made and some recommendations have been given as to the proper tuning of the model. The problems arising in modelling complex weaving structures and in simulating their deformation behaviour have been discussed. The creation of an accurate geometric and mechanical model of a terry fabric aims to predict its behaviour, especially in compression and assessing the change of softness during softening treatment.

Keywords— simulation modelling, terry fabric, deformation, finite element method, touch, softening

I. INTRODUCTION

Just like many other industries, terry fabrics production can make use of computer modelling to significantly facilitate and shorten the development process, searching for the most appropriate structures, structural parameters and finishing processing.

For this purpose computer models of terry fabrics have been developed in various processing stages – raw fabric (directly taken down from the loom), washed and softened [23, 24]. Simulations of fabrics behaviour in compression have been carried out, aiming at an adequate computer model that can allow evaluating the impact on softness of structure changes and different treatments.

The study is focused on assessing the degree of compression and softness, as many studies have shown that a main quality indicator of this type of fabrics, besides the sorption property, is touch [7, 12, 30]. This fact is confirmed by the significant amount of research, carried out by chemical companies, which

led to the development of a wide range of textile softeners [16, 31].

The mechanic behaviour of terry fabrics is a field, which is insufficient researched. The most publications present results from determination of their properties and analysis of the influence of different factors and parameters on them [1-2, 14-15, 20-21]. Computer modelling and simulation of their behaviour under stress and deformation till now is not reported.

Such investigations are carried out for a lot of other textile structures as woven and knitted fabrics [8, 10, 13, 14, 17-18, 22], as well as composites [3-6, 29]. For modelling of their structures are used specialized (like WiseTex) or universal (like AutoCad, SolidWoks, etc.) software products.

One of the most used method for studying and analysing of the stress-deformation behaviour is the Finite Element Method (FEM) [3-6, 8, 10, 19]. It is suitable for solving of these problems, but requires a preliminary answer of many questions arising in the modelling process. Most of them are linked to the model pre-settings including definition of the boundary conditions, meshing parameters, solver's tuning parameters, etc. They are very important for obtaining of correct results, but often are not presented in the papers or are mentioned too briefly.

The aim of this paper is to mark and analyse the problems arising in the simulation modelling of the terry fabrics structure giving possible solutions or approaches.

II. METHODOLOGY

The modelling process is carried out in the following order:

A. *Measurements (done for each fabric separately)*

- 1) Taking samples from the fabric.
- 2) Capturing different parts of the fabric and separate threads, carefully taken out of it, by means of a digital microscope with appropriate magnification.
- 3) The resulting images are carefully observed and measured, in order to specify the yarn diameters and the fabric geometry. This information is used in geometric modelling.

4) Young's modulus and Poisson's coefficient of cotton threads are determined experimentally. This information is used in simulation modelling.

5) Terry fabric behaviour during compression is experimentally determined. This information is used for verification, evaluation and correction of computer generated models.

B. Geometric modelling

1) A conceptual model is created, taking into account the weave type (the order of threads interlacing) and the size of the repeat in the warp and weft direction.

2) The raw fabric is modelled.

a) The individual threads are modelled: axis drawings with the necessary relations are created. Data are used from the fabric's technological setting and experimental data.

b) The threads are assembled. Their mutual location and distances are set. The data used are from the fabric's technological setting as well as experimental data.

c) The assembled model is checked for collisions. If any, minor adjustments are made in the drawings of the threads and the distances between them.

3) The washed fabric is modelled (obtained by laundering of the already tested and modelled raw fabric). Includes the same sub-stages, as the modelling of the raw fabric.

4) The softened fabric is modelled (obtained by softening of the already tested and modelled washed fabric). Includes the same sub-stages, as the modelling of the raw fabric.

C. Simulation modelling

1) The geometric model is imported in the CAE-system.

2) The initial conditions are set.

a) The material properties are assigned.

- Young's modulus for steel and cotton;
- Poisson's coefficient for steel and cotton;
- Friction coefficient cotton/cotton and cotton/steel;

b) The connections between the individual details are assigned. These include contact pairs from surfaces, which have been in contact from the beginning of the simulation, as well as pairs that are expected to come into contact during the deformation process. Contact parameters are set.

- Connections between individual threads;
- Contact of pile threads between them;

• Connections between piles and clamping plates.

3) Boundary conditions are set.

a) Interaction of the warp with the environment – weft and warp threads are fixed into space (at their ends or otherwise).

b) Interaction of the pile threads with the environment – choice can be made among different options (solid fixing, flexible fixing, regular repeating, elastic elongation etc.)

c) Interaction of the clamping plates with the environment – the plates are devoid of all degrees of freedom of movement, except movement perpendicular to the warp.

4) Meshing

a) The finite elements type, the meshing method, as well as other settings of the meshing algorithm are specified;

b) The finite elements dimensions are set by details.

c) Then follows meshing.

d) The resulting mesh is being analysed – type, number, shape, location and dimensions of the finite elements. If necessary the settings are readjusted and darning is repeated.

5) Setting the load on the two clamping plates.

6) Tuning the solver (calculation algorithm). This includes settings such as: initial, minimum and maximum number of iterations, solver type, weak springs' parameters, type and values of the convergence criteria, type and frequency of result recording etc.

7) Solving the resulting problem. Depending on the complexity of the task and the specific definition, this could take from a couple of minutes to days. The necessary time for problem solving, as well as the presence of solution convergence, are key parameters for model definition, tuning and optimization.

8) Visualisation of the results obtained.

a) The figures corresponding to the values of the clamping plates' movements are given in tables and graphics. This type of data is most appropriate for comparison with the experimentally established fabrics behaviour during compression.

b) The model deformation (total deformation) is displayed as colour scale images. This type of result presentation allows an easy visualization of the results obtained.

c) The model deformation process under gradual increase of the load in time from zero to its maximum value is recorded in a video file. The process visualization can be used for control and analysis of the deformation process.

9) Verification and analysis of the results obtained.

a) Visual evaluation of the deformation process. By observing the process videos it can be verified whether the model behaviour is physically plausible. If anomalies are detected a search for errors is carried out, adjustments are made in the task definition, and then the evaluation is repeated.

b) Comparison of the simulation results with the experimentally established fabrics behaviour during compression. The numerical values of the experimental and simulation results are graphically compared. The established divergences are evaluated and the reasons for them are analysed.

10) Correction of the model. In case of significant divergences and after a thorough analysis of the reasons for this, the model is readjusted and the calculations are repeated. Corrections are made to the:

a) Geometric model. Due to the hairy structure of the threads and the variety of shapes and sizes of the piles, some parameters of the geometric model, significantly affecting the simulation results, are quite provisional and roughly determined:

- Height of the pile in absence of pressure;
- Thread diameter;
- Pile shape.

b) Geometric model configuration. The number and location of repeats in different directions (for example 3x3, 2x2, 4x1, 2x1) affect the simulation results due to differences in the specified interactions and boundary conditions influence.

c) Initial and boundary conditions. After varying and exploring different options the following are specified:

- Support of pile threads;
- Support of threads in the warp;
- Warp behaviour. Considering the warp as non-deformable (completely or partially of some threads) brings a certain error in the simulation, but greatly simplifies the task and is thus one of the ways to optimize the model.

Stages „Measurements” and „Geometric Modelling” for the raw fabric are presented in detail in [24-25]. Below will be discussed only some new and specific moments that are directly related to the modelling of the washed and softened fabrics.

III. MEASUREMENTS

The following characteristics required for the simulation modelling are determined:

1) *Weave and repeat size* in warp and weft direction;

2) *Diameters of the threads* – special attention should be paid to the correct determination of the

outer diameters, because they define the contact zones;

3) *Length and form of the threads' axes* ensuring the real coefficients of weaving-in;

4) *Length and form of the pile thread* - main geometrical measures in 3D.

5) *Deformation curves* describing the rate of compression of the terry fabrics;

6) *Material properties* - modulus of elasticity of the yarns after treatment, coefficients of friction, etc.

The data for drawing up the experimental deformation curves are obtained by means of Digital Thickness Meter D-2000, Hans Schmidt & Co GmbH, varying the pressure load from 0.1 to 1 kPa in steps of 0.1 kPa. The lower and the higher load values are achieved with the standard weights supplied and the intermediate - by placing calibrated weights on the loading plate.

The experimental curves were approximated to standard trend-lines. Best matching ratio showed the power function.

While determining the value of the elasticity modulus E , there arise a number of problems that have to be solved, namely:

1) *Deformation type specification*. It is obvious that the threads are subjected to a complex load, including bending, torsion, tension/pressure and in some areas - shear. Since it is practically impossible to determine the elasticity modulus for such a complex load, the rational approach is to specify the prevailing load and to carry out the necessary research to determine the elasticity modulus. As the main deformation is related to the pile structure bending, so the elasticity modulus is determined for thread bending.

2) *Choice of study method*. There are various schemes for studying thread behaviour during bending [26]: the thread can be viewed as a beam on two supports; a beam fixed at one end, bending under its own weight or under the effect of an applied force; by measuring the deflection, the force or the bending moment. The analysis of the existing methods has shown that the most appropriate method is the one in which the thread is restrained at one end, bends under its own weight and then the deflection length is measured. (Fig. 1). This method is simple to implement and gives relatively accurate results.

The bending modulus of elasticity is defined as a relationship between stiffness B and moment of inertia I :

$$E_b = \frac{B}{I}, \quad (1)$$

and in turn these are defined as:

$$B = \frac{F \cdot l^3}{8 \cdot f_b} \text{ and} \quad (2)$$

$$l = \frac{\pi \cdot d^4}{64}, \quad (3)$$

where: F is the thread weight, mN;

l - the thread length, mm;

f_b - the thread deflection, mm.

The bending modulus of a raw fabric pile thread is 157MPa, and that of the same but washed one is 141MPa.

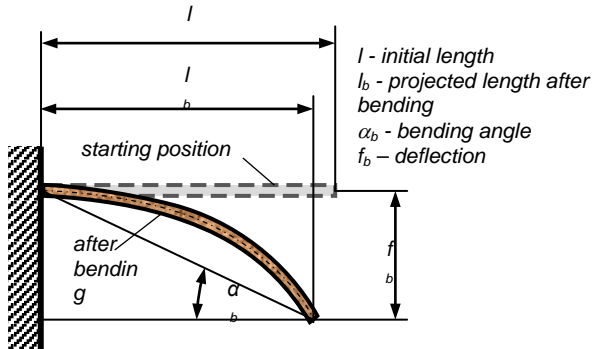

Fig. 1 Scheme of bending modulus determining

While defining the E_b there arise some problems related to:

1) *sampling* - threads should be pulled out very carefully from the fabric structure, so as not to make a "concealed" withdrawal, and then should be left to relax in order to eliminate any distortion caused by their stay in the fabric structure;

2) *inaccurate determination of the moment of inertia* due to the non-circular cross-section of the thread.

Measuring only the bending modulus of elasticity and neglecting the other loads, as well as the insufficient precision in its determination, leads to inaccurate determination of the threads elastic modulus and to a need of adjusting the obtained value.

IV. GEOMETRIC MODELS

Fig.2a shows the conceptual model of the fabric. The three thread systems making up the fabric are set – warp, weft and pile, as well as their interlacing order.

The modelled weave is rep $\frac{2 \bullet}{\bullet 1}$, and each repeat involves 2 warp, 3 weft and 2 pile-forming threads (one for the upper and one for the lower pile surface). Fig.2b illustrates the model of the raw terry fabric, with specified geometric shapes and dimensions. Fig.2c illustrates the model of the same fabric, but after washing. As it can be seen, washing has led to a change in shape and size of the piles (a characteristic torsion), as well as to a change in the warp structure geometry. Fig.2d shows a model of the same fabric after softening. The pile shape is further complicated, the pile becomes more twisted (8-shaped).

A. Geometric modelling of warp threads

Fig.3 shows a drawing of a softened fabric thread axis. All lines in the drawing are in black, which means that it is completely defined (contains exactly the required number of connections) and any modification of a geometric dimension results in automatic change of the free distances, thus preserving the overall shape of the axis.

The use of a fully determined drawing allows quick and easy corrections in the model geometry and is a prerequisite for avoiding errors and collisions. These advantages are also manifested in modelling fabrics, in which geometric dimensions vary depending on the treatment, as well as in other similar cases.

B. Geometric modelling of pile threads

Modelling the pile shape is a complex and laborious process. The successful solving of this problem requires compliance with the following requirements:

- 1) selection of a representative shape, which should be closer to the average shape of the real piles, as they differ greatly from one another;
- 2) length and height of the pile, equal to the measured ones;
- 3) avoiding self-intersection of the pile body;
- 4) smooth and natural curves;
- 5) giving a shape, allowing a proper meshing. The cross section should be able to follow freely and smoothly the axis, otherwise the thread diameter becomes variable in areas, where following the axis gets difficult.

Meeting these requirements is not an easy task when complex 3D shape-spline curves should be modelled. This requires creation of an appropriate methodology for generating the desired curve.

Fig.4 shows the spline-curves used for creating the studied fabrics' piles. As the curve shape becomes more complex, a larger number of knots are to be used (7, 13 and 16 knots respectively). Additional means are required to control the exact position of the knots, in order to obtain smooth and natural curves:

- 1) the axis shown in Fig.3b has been created using an axial polygon, connecting the knots for initial rough placement of knots in space.
- 2) the axis in Fig.3c has been created using a subtle control of knots position by manipulating the numerical values of their coordinates (x, y, z) with an accuracy of 0.0001 mm. The angle of the tangents to the end knots is also controlled. A tool called "Relax spline" has been used to automatically adjust the polygon of tangents to the spline line. This tool facilitates the obtaining of smooth and natural curves.

Fig.5 shows drawings with laid out geometric dimensioning and general appearance of the modelled softened fabric threads (the upper and the lower pile threads have identical shape and dimensions).

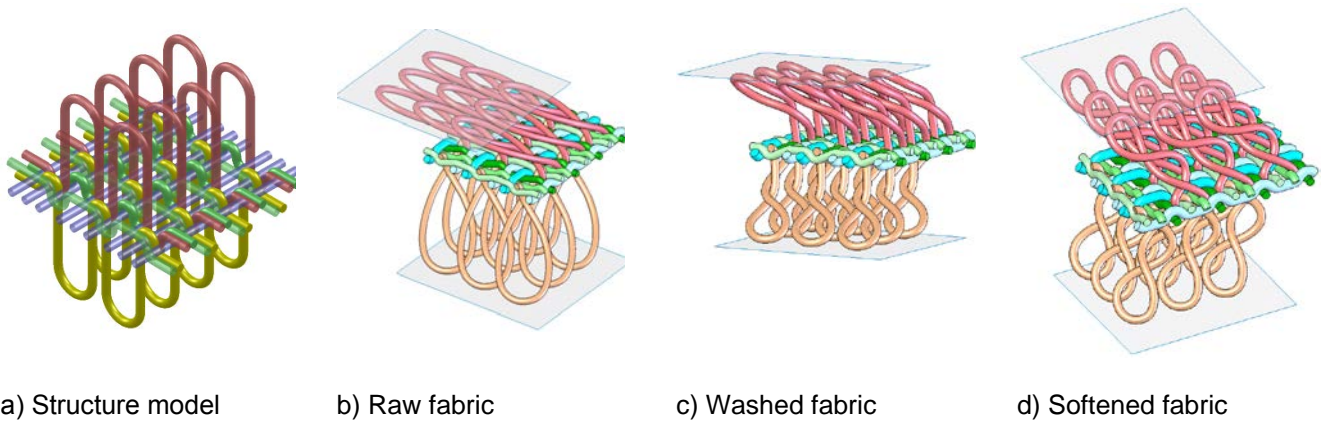

a) Structure model b) Raw fabric c) Washed fabric d) Softened fabric

Fig.2 Geometric models of terry fabric – common type

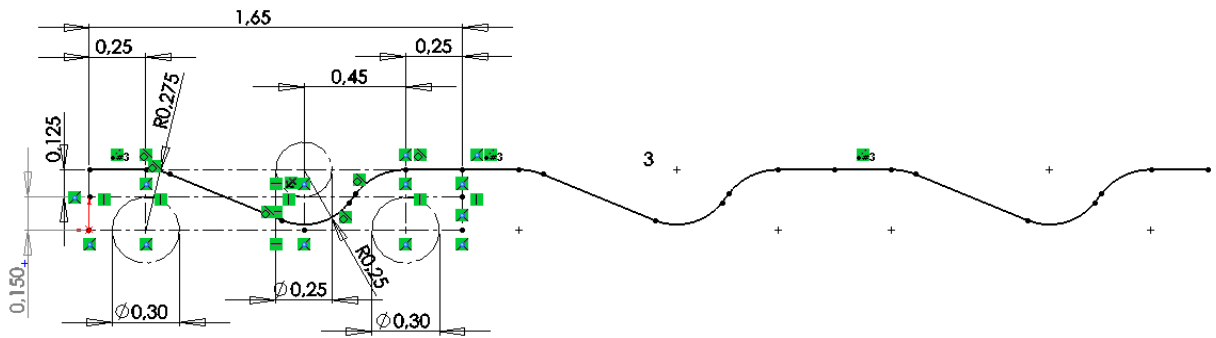
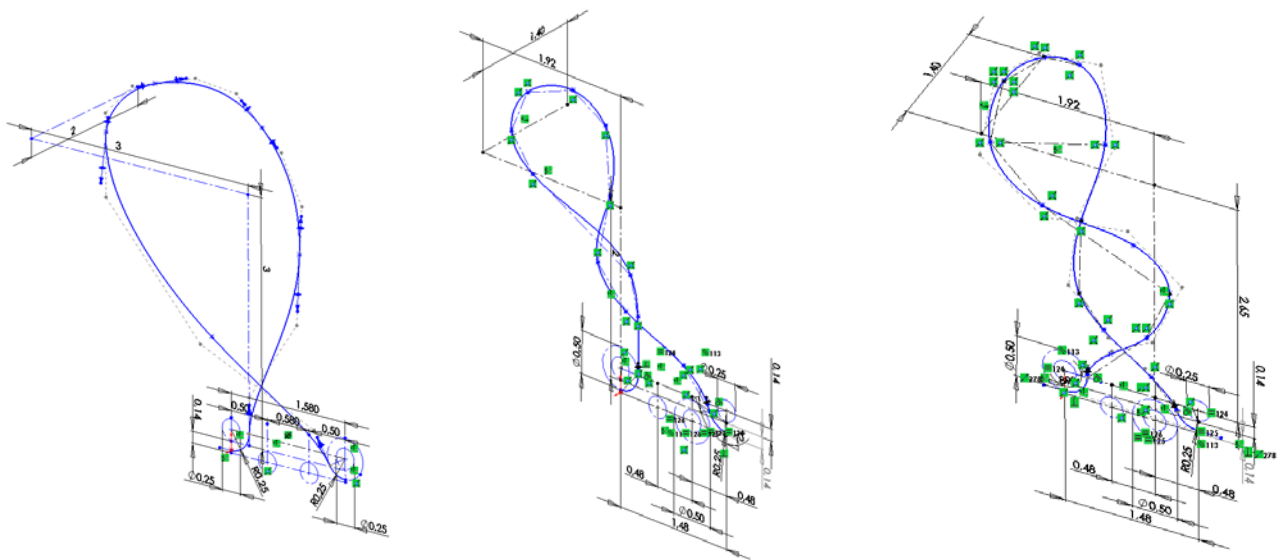
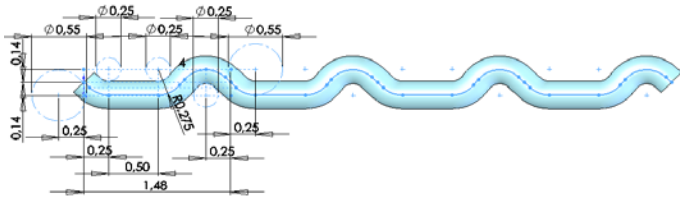

Fig.3 Drawing of a thread with the required number of connections



a) Raw fabric pile with 7 knots b) Washed fabric pile with 13 knots c) Softened fabric pile with 16 knots

Fig. 4 Axes of pile threads



a) First ground warp thread

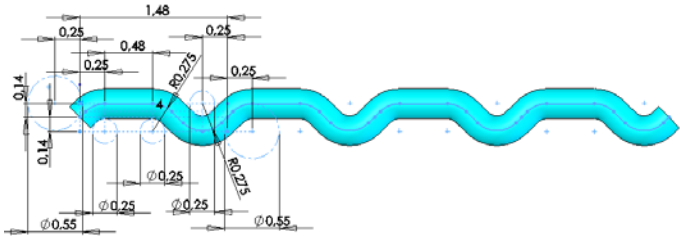

b) Second ground warp thread

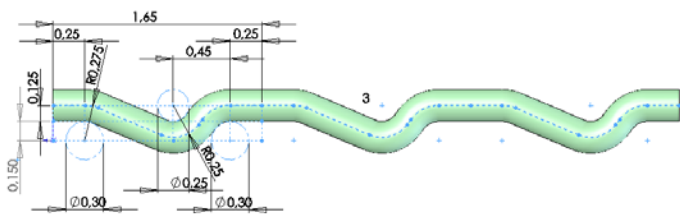

c) First weft thread

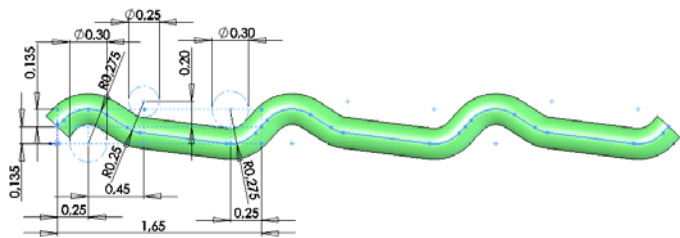

d) Second weft thread



e) First and third weft thread

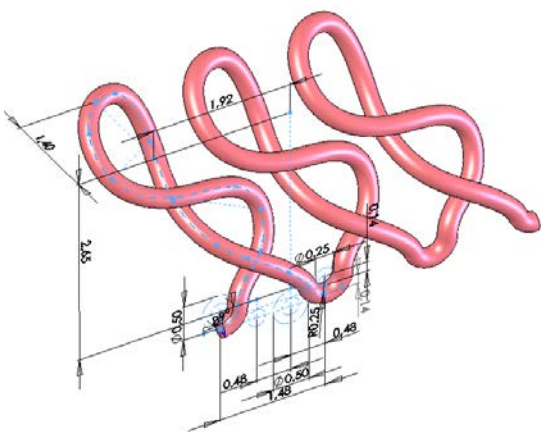

f) Pile thread

Fig. 5 Shape and dimensions of softened fabric threads

V. SIMULATION MODELLING

After creation of the geometric models we pass to the simulation modelling, according to the above given sequence. Many problems arise during the simulation model definition, some of which are discussed below.

A. Setting material properties – Young's modulus E

Fig.6 shows the influence of the elastic modulus E on the simulation results. It can be seen that this influence is considerable both on the shape of the deformation curve and on the maximum deflection value. Therefore, its precise determination is essential for obtaining an adequate result from the simulation. On the other hand, setting the real value of E in the geometric models, as shown in Fig.1, leads to inaccurate results, due to the disregard of hairiness and additional contacts between the threads.

The choice of an appropriate adjustment of the parameter E is the milestone in computing model improvement for achieving adequate results with complex geometries and presence of additional final processing operations. Reaching the appropriate value is connected to:

- 1) accurate experimental determination;
- 2) setting the experimentally determined value in an adequate computer model;
- 3) detailed analysis of the results obtained after comparison with the experimentally determined behaviour during compression;

4) if necessary - adjustment of the E value, a second simulation and repeated analysis. Usually, the appropriate E value is reached after several iterations.

B. Setting material properties – Poisson's ratio ν

The Poisson's coefficient value is fixed to 0.3. For polymer fabrics it depends greatly on the extension degree and varies widely – from 0 to 1.18 [27]. The value 0.3 is appropriate for relative elongation of 2-3%. At the same time the Poisson's ratio influence on the simulation results is insignificant, as the threads are mainly subjected to bending and torsion.

C. Setting material properties – Coefficient of friction μ

The friction coefficients also vary widely depending on the type of the material, its structure, the final processing of the fabric, humidity and other factors [9, 22, 23, 26, 27]. As a reference, the static friction coefficient for cotton-steel is in the range between 0.2-0.3, and for cotton-cotton – between 0.3 and 0.7 [23]. This parameter, along with the geometry of the structure, is greatly influenced by the softening treatment. It has a considerable share in the subjective feeling of softness of terry fabric, which is an important characteristic for the users.

The preliminary studies have shown that the friction coefficient practically does not affect the simulated behaviour of the fabric at compression (Fig.7). The explanation is, that the idealized to cylinders cotton threads touch and rub each other in points or lines, and not in surfaces, as it is in practice.

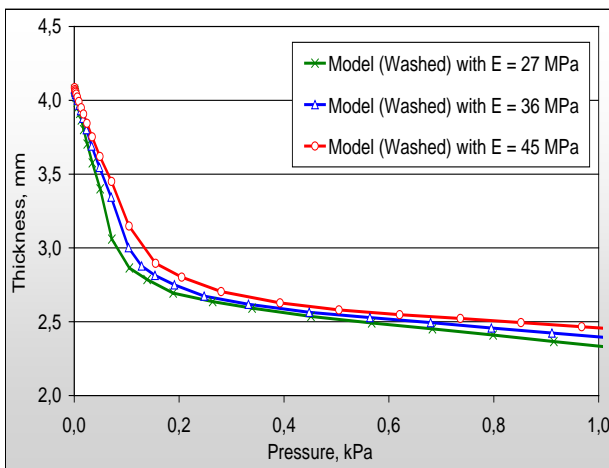

a) Small changes in E for washed fabrics

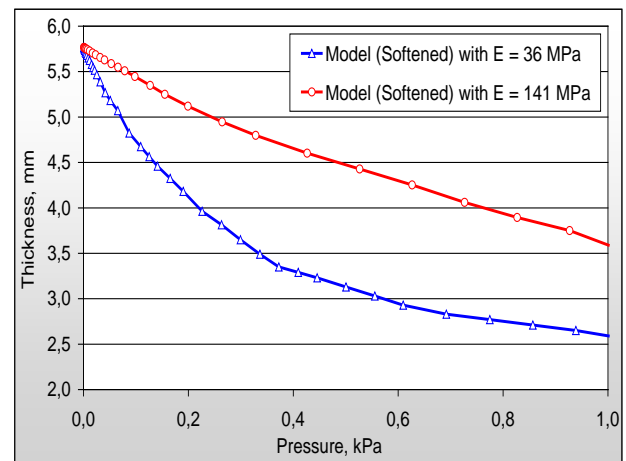

b) Big changes in E for softened fabrics

Fig. 6 Influence of E on terry fabrics deformation behaviour

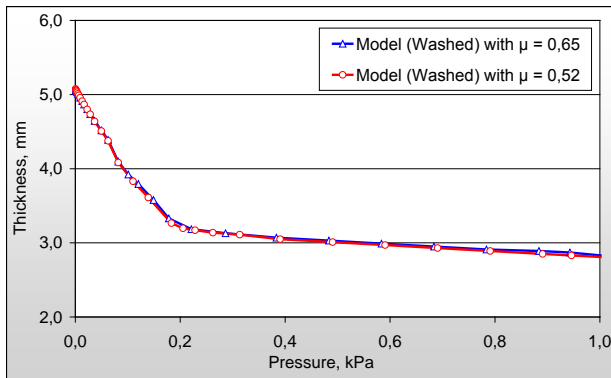

Fig. 7 Influence of the friction coefficient cotton-cotton on terry fabric behaviour at compression

D. Defining connections

When defining connections we take into account both those existing in a free state and those that will occur after deformation of the fabric during compression. This is illustrated in Fig.8. Besides the two surface groups (contact and target), whose relationship is being defined, a number of contact parameters are set, as type (frictional), friction coefficient etc.

E. Boundary conditions

An important prerequisite for solution convergence is to have fabric uniformity of behaviour during compression. This requires defining the boundary conditions (fixing) for each thread. The simplest option is to fix the threads at the ends. This, however, brings some unreliability in the model – the impossibility of the threads to move and twist at their ends, as it is in reality, is a serious weakness. With respect to the warp and weft threads this is not a major problem, because they deform slightly. For the pile threads, however, this can significantly distort the results, as in reality they may be twisted around their axis at the beginning and at the end of each repeat, and thus they may bend more with less force, than if they were fixed.

There are several approaches to overcome this problem, and after carrying out some numerical experiments, the most appropriate among them can be chosen:

1) *Geometric model with a greater number of repeats.* The influence of the fixed ends will be thus decreased. Even though it seems the most logical one, this approach is not applicable due to the great increase in the calculations complexity.

2) *Elastic fixing of all ends.* If the elasticity of the connection is correctly selected, this approach will allow the ends to move roughly in the same way in which they would move if they were connected to an adjacent repeat.

3) *Elastic fixing of some ends.* Considering that the fabric will be subjected to a pressure load, one of the ends of each thread is "attached" to the weft

thread, and the end remains free or just a few degrees of freedom are taken away (Fig. 9). This will create no computing problems, if the other end of the thread is fixed by suitable elastic support.

4) *Defining periodic regions.* Since the fabric is composed of numerous identical repeats, defining the periodicity is a powerful approach, bringing reliability to the modelling, while eliminating the need for simulating a great number of repeats. This approach, however, does not solve the problem with the attachment of the threads.

5) *Ignoring the problem.* It is possible to establish that the model with fixed ends gives satisfactory results. Since this model is the simplest one, does not cause any problems with the convergence and its solving takes the least amount of time, it could also be used.

The most appropriate approach appears to be that with the elastic fixing, which is done by adding at the end of the thread a cylindrical body with the same diameter, but with the possibility to change its length and elasticity. The body will thus be able to participate in the contact with the corresponding weft thread, which improves the reliability of the model.

Fig.10 shows the results from simulations with different boundary condition combinations for pile threads. An experimentally determined deformation curve is also given.

The results from Fig.10 show, that:

1) The elasticity modulus E of the support significantly affects the fabric behaviour at compression. The elastic support allows the thread to bend quickly initially in applying only a slight effort. Subsequently, after its contact with the adjacent threads, the model becomes stiffer.

2) When the value of the support elasticity modulus is great (equal to that of the thread), the fabrics behaviour is the same as with firmly fixed end, so adding elastic support becomes useless.

3) A too small E value distorts the results at the beginning and creates numerical problems to the solution, arising from the poor attachment of the thread.

4) Certain E values of the support give a relatively smooth bend at the beginning of the curve, such as the actual fabric behaviour. When the end is firmly fixed, the deformation is linear from the beginning, which is implausible.

5) The presence of a free end „softens” the model, making it easily deformable even at slight effort.

The conclusion is that the elastically fixed end improves the model quality, and the support elasticity modulus with the chosen additional body length (1 mm) should be lower than that of the thread. Its value should be such that the total deflection at a thread end

point is equal to that at the analogous point of an adjacent repeat, farthest from the edges.

Additional calculations have been made in order to determine whether the second end of the thread should be left free or also elastically connected. These

F. Meshing

By careful tuning of the elements density within the volume and on the thread surface, a network is obtained, wherein each elementary cylinder is represented by a sixteen-sided prism with five knots

are made for washed fabric, for models with repeats 2x2, with unilateral or bilateral fixation of thread ends and change of the support elasticity modulus. The best shape of the curve is obtained when the attachment of the pile thread is bilateral. This type of attachment will be therefore used in the final model. Inside. Compared to older models (with nine knots inside) the total number of finite elements and knots has been significantly reduced, without thus affecting the net density on the thread surface and hence - the accuracy of the solution. This improvement is illustrated in Fig.11.

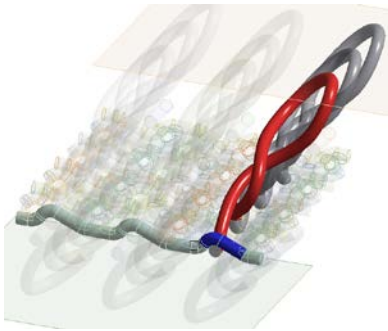

a) Fixed end of the pile, 3 target-surfaces

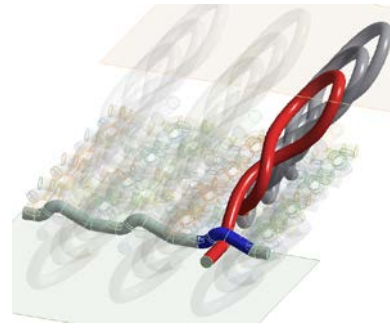

b) Free end of the pile, 4 target-surfaces

Fig. 8 Defining pairs of surfaces in contact: contact (in red) and target (in blue)

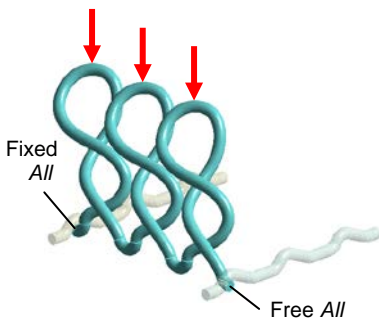

a) A model with one fixed and one free end

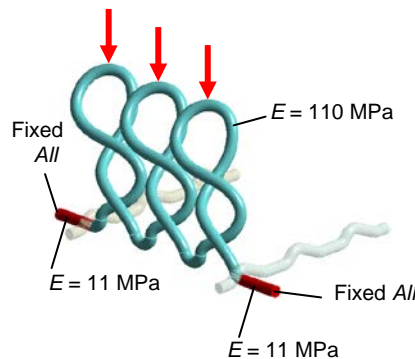

b) A model with elastic supports at both ends of the thread

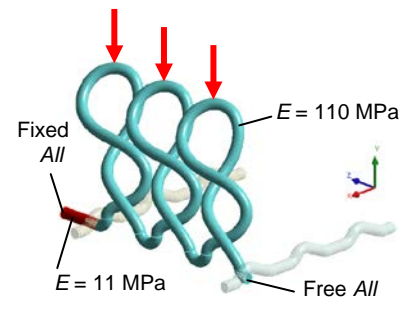

c) A model with elastic support at one end and a free second end

Fig. 9 Types of boundary conditions

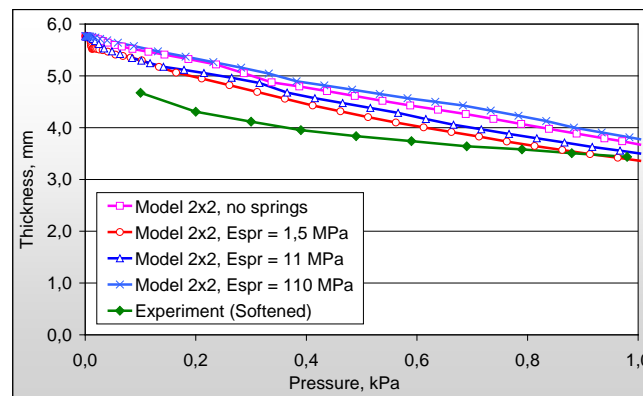

Fig.10 Boundary conditions impact on terry fabric behaviour at compression

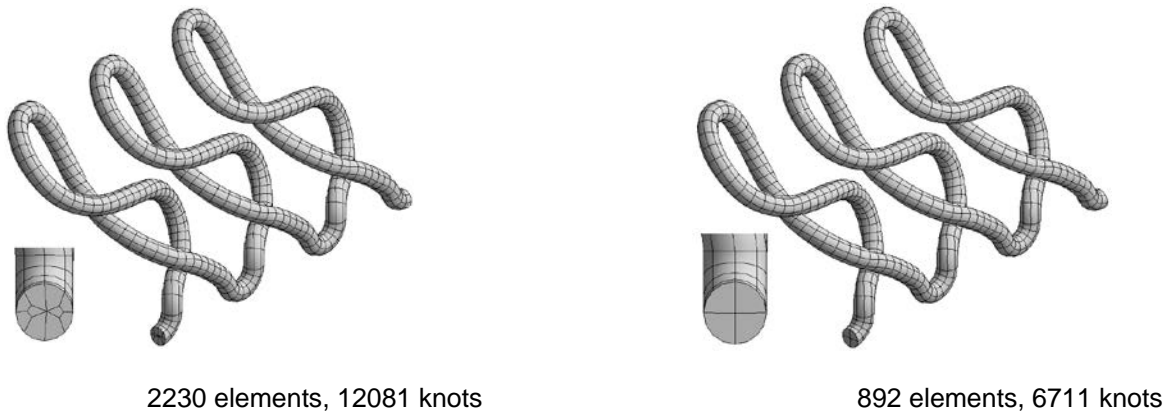

Fig. 11 Mesh optimization

G. Visualisation of the simulation results

Fig. 12 shows the deformation moment of modelled washed fabric at compression load. This figure visualizes the fabric deformation, but does not allow an objective assessment of model relevance. Another two types of visualisation are needed for such an assessment.

1) Graph of fabric thickness under compression load – for example Fig.10. This type of visualisation allows an easy comparison and analysis of the simulation results with experimental data for the same fabric.

2) A video, showing fabric deformation at even increase of the load as function of time. Its careful monitoring allows model physical adequacy control, error detection in contacts definitions, studying the complex of interactions occurring in the course of deformation.

All three fabrics required additional model improvement. Some problems and solutions that can be attributed to all models are given below.

I. Adjusting the pile height

As it can be seen from Fig.10, the curves, resulting from the simulations, especially at low loads, are well above the experimental curve for washed fabric. This is due to incorrect setting of pile height and fabric thickness at unloaded state. This error is not surprising – due to the great hairiness and huge variety in pile location and shape, the precise measurement of fabric height in free state is very difficult.

As a result of the analysis made the washed fabric model height has been adjusted from 5.77 mm to 5.08 mm.

Fig.13 shows the results from simulation with two different initial heights, all other conditions being equal. It can be seen from the figure that:

1) under small to average compression load, the curve of fabric with height 5.08 mm practically coincides with the experimental one;

2) at high load values, the revised model is considerably „softer” than expected, even though the same elasticity modulus value E has been used, as in the previous calculation;

3) at average load levels there is a horizontal area in the curve, i.e. the fabric does not decrease its thickness, despite of the increasing load. This is due to model piles mutual relocation with respect to one another. Such „sliding” does not really occur, which is indicated by the experimental deformation curves.

The deviations registered in the curve under loads above 0.5 kPa show insufficient model stiffness at high loads. Two adjustments can be done in order to increase the stiffness:

1) *Adjusting the pile shape.* Expansion of the pile in the lower part will increase the contact between the piles and will "stiffen" the structure at great deformations;

2) *Increasing the number of repeats in the model,* which will lead to more contacts between the piles.

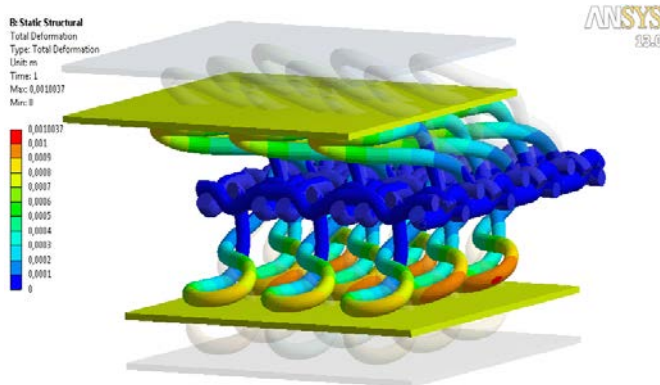

Fig. 12 Simulation of washed terry fabric behaviour at pressure

H. Analysis of the results from the simulation modelling

The present study covers three different fabrics – raw, washed and softened. Comparison, evaluation and analysis of the results are made for each separately. These analyses are very concrete and detailed, so they will not be exposed here.

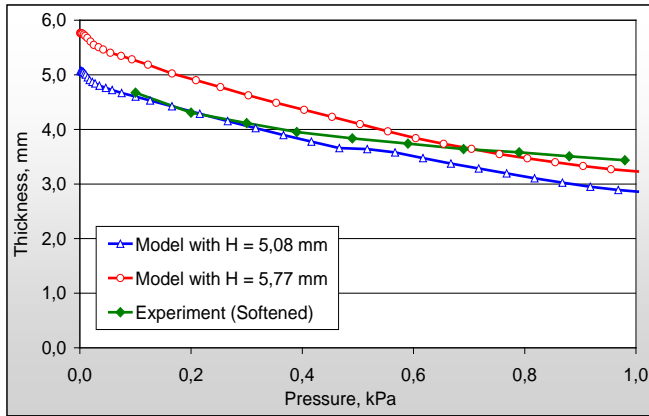
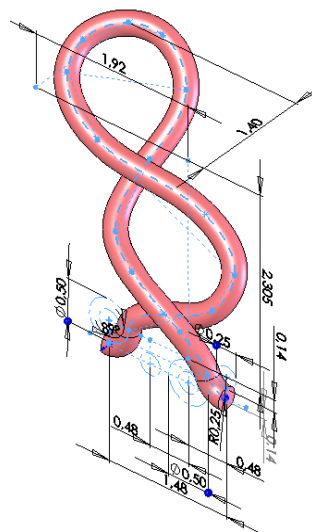

Fig. 13 Comparing models with different initial fabric thickness

J. Adjusting the pile shape

A model with 2x2 repeats has been used, with some changes in the pile shape, preserving the initial fabric thickness of 5.08 mm. The thread length in the repeat has been also preserved, as well as its experimentally determined overall dimensions. The other threads have not been changed. The new geometry is shown in Fig.14.



a) Processed pile geometry

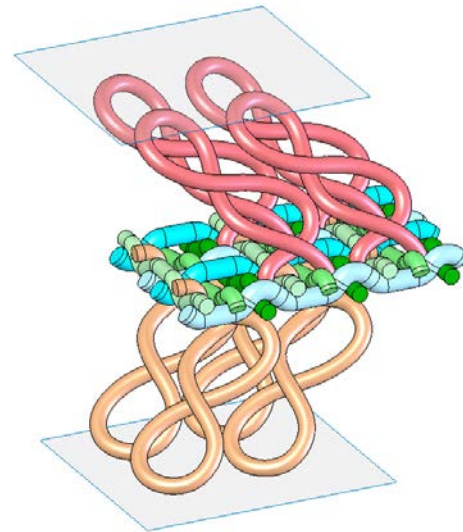

b) General appearance of the geometric model

Fig. 14 Geometric model of a fabric with initial thickness 5.08 mm

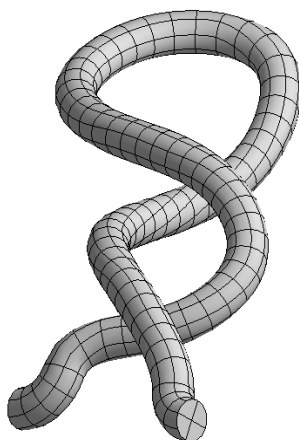

a) Pile before the change

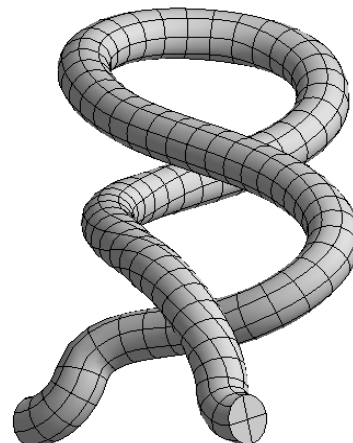

b) Pile after the change

Fig. 15 Correction in the shape of a softened fabric pile

The new shape of the pile gives two additional advantages:

1) Thread intersection is made with minimum distance (see also Fig.15), so that the pile will come into contact with itself at two points with very small deformation. In the previous models there was no second contact point, and now there is one in the middle of the pile as well

2) The pile is expanded in the direction of the base. In this area it is expected the pile to touch the adjacent pile of the same thread with a very small deformation. In the previous models the contact between two adjacent piles occurred with significant deformation.

It is expected that these changes affect significantly the fabric behaviour at compression and result in a „stiffer” structure.

K. Choice of model configuration

The simulation realism increases with the increase of the number of piles. The share of the piles, which at deformation contact with adjacent threads on all sides, also increases, i.e. this complies with reality. In modelling however, the border piles on one side contact with the empty space. The following examples, given below, are for the ratio between the number of piles, contacting with the adjacent ones, and the number of those that during modelling are not in contact, due to the fact that the contact is outside the modelled space:

1) for model with 2x2 repeats - 0:4 – Fig.16a;

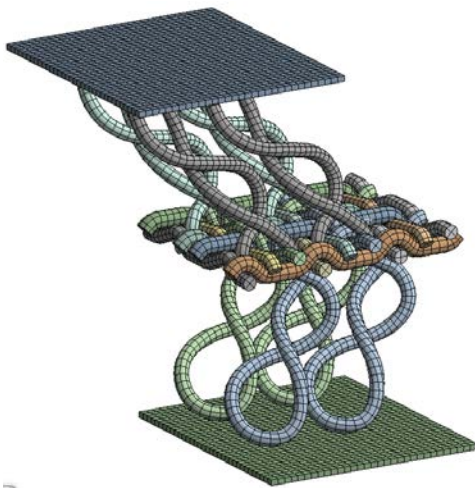

a) Model 2x2 repeats with 6800 finite elements

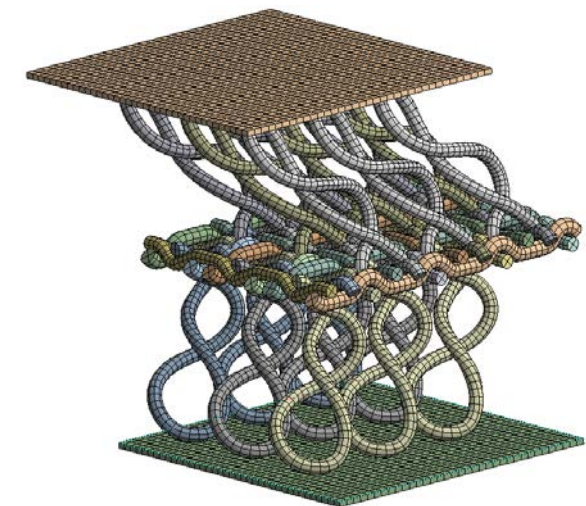

b) Model 3x3 repeats with 12600 finite elements

2) for model with 3x3 repeats - 1:9 – Fig.16b;

3) for model with 4x4 repeats - 4:16.

Furthermore, with the increase of the number of repeats in the model, increases also the length of the warp and weft threads, having a more realistic behaviour, as the ends at which they are fixed go farther. At the same time this increase leads also to a significant increase of the finite elements number and the time for calculation (the ratio of the solid-state finite elements is approximately 8:18:32, respectively for 2x2, 3x3 and 4x4 repeats). The task is further complicated by the increasing number of contact surfaces and contact finite elements. Problems also arise with the solution convergence.

The goal is therefore to evaluate the model complexity influence on the accuracy of the simulation of terry fabric behaviour during compression, through numerical experiments, and choose the simplest geometry which gives satisfactory results.

In Fig. 16c are compared the results from the simulation with geometric models of different complexity (2x2 and 3x3) for softened fabric. It can be seen that the maximum deviation in the simulated fabric thickness is about 4.4%, while the difference in the finite elements number and the time for calculation is roughly double. This shows that the use of complex geometry in order to increase the model accuracy is not very appropriate solution, especially in the initial stages of tuning the model parameters.

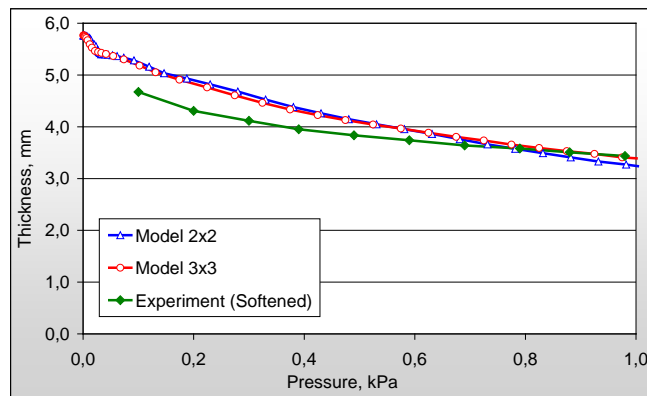

c) Change of thickness during change of pressure on the fabric

Fig. 16 Impact of the modelled repeats number on the results

For raw and washed fabric the use of a model with 2x2 repeats is a good enough solution. For the softened fabric, shown in Fig.17, the following particularities can be observed:

1) Adjacent pile threads from the same side of the fabric, even if with maximum deformation, do not come into contact with each other;

2) Pile threads do not come into contact with the warp threads;

3) Pile threads of the same row have significant contact.

These observations give ground for further simplifications, which will release computing resources to increase the number of repeats.

1) Pile thread deformations of a given row do not depend on the deformations on the adjacent row, so it is sufficient to simulate just one pile row, consisting of an upper and a lower pile thread;

2) Threads from the base structure do not influence the deformation of the pile threads and can be therefore removed from the computing model.

3) As a result of the simplifications made a model of softened fabric with 4x1 repeats has been built, shown in Fig.21a.

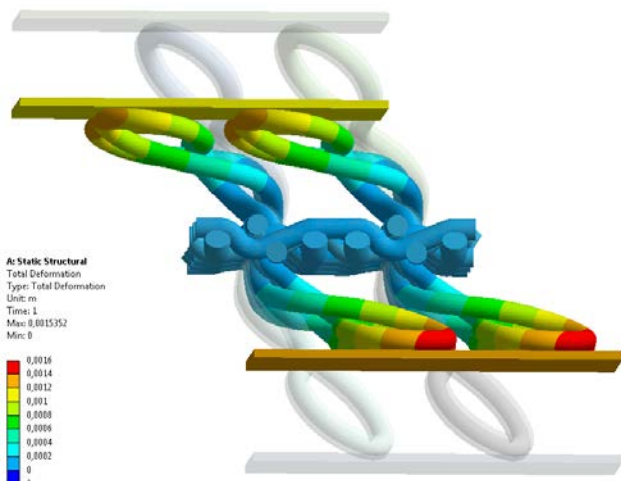

Fig. 17 Simulation model at maximum load value

L. Adjustment of the initial conditions

In the search of a more productive solution there is another option to adjust the model without considerable loss of accuracy, and that is the simplification of the interactions at the base. The ground warp and weft threads contact with each other on multiple surfaces and get deformed under the piles pressure. These deformations, however, are relatively small, while the time needed for their calculation is considerable. Therefore it is possible to consider the warp and weft threads as non-deformable, and thus the contacts between them become irrelevant and may be omitted in the modelling.

Fig.18 shows the results from the simulation with stiff and deformable base. It can be seen that the simplification results in an error of the order of 4-5%, while the computing time saving reaches 60%. The option with non-deformable base is adopted for the model 4x1 of softened fabric, shown in Fig.21a.

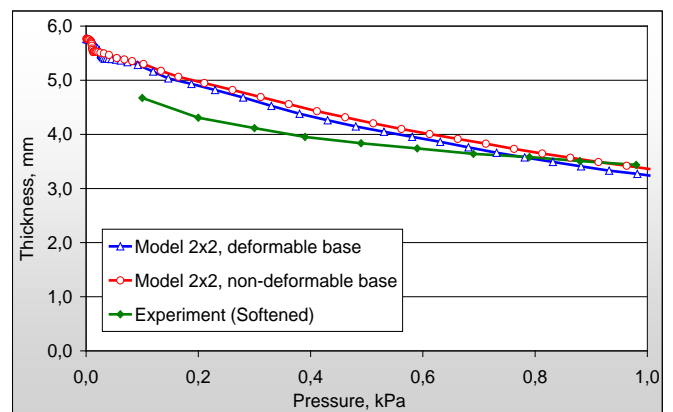

Fig. 18 Results with and without taking into account the deformations in the basic structure

M. Final results after adjusting the models

Figures 19 and 20 show comparisons between simulation and experimental results for raw and washed fabrics respectively. The final versions of the models made are used. As it can be seen from the figures, almost a complete matching is achieved for

the raw fabric, while the mismatch for the washed fabric, especially in the first half of the load, is considerable, though not big. The reasons for this may be in the complicated geometry and its more inaccurate modelling, as well as in the unsatisfactory selection of material constants and model settings.

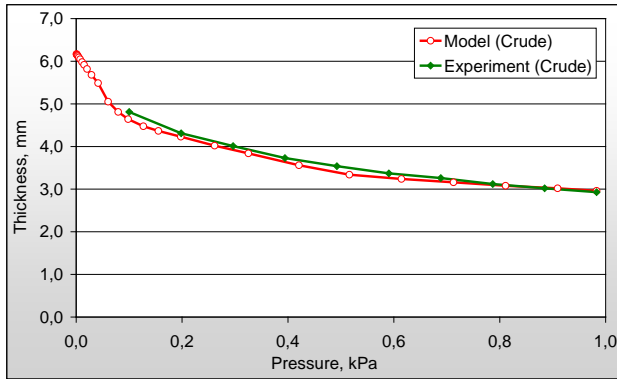

Fig. 19 Raw fabric behaviour at compression

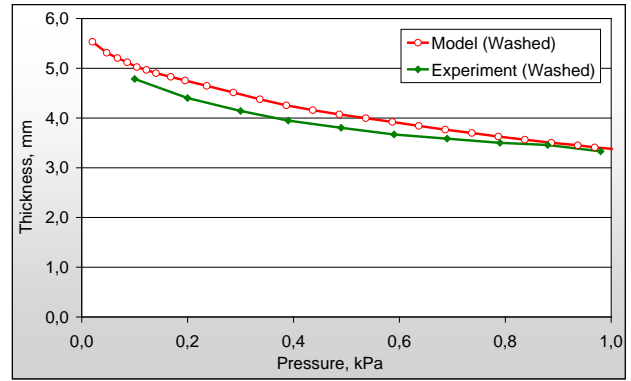
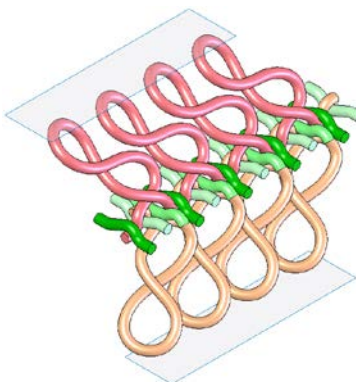

Fig. 20 Washed fabric behaviour at compression

Fig.21 shows the general appearance and the results from the simulation of softened fabric model with 4x1 repeats. The model includes non-deformable and fixed in space weft threads with a length of one repeat, which contact with the piles. The pile threads themselves are restrained with an elastic support at one end, while their second end is free.

It has been seen that the simulated behaviour of terry fabric comes to a great extent close to reality. The maximum deviations are in the range of 7%. The simulated curve in its middle part is near to a straight line, which is explained by simplification of the base and the pile shape.



a) General appearance

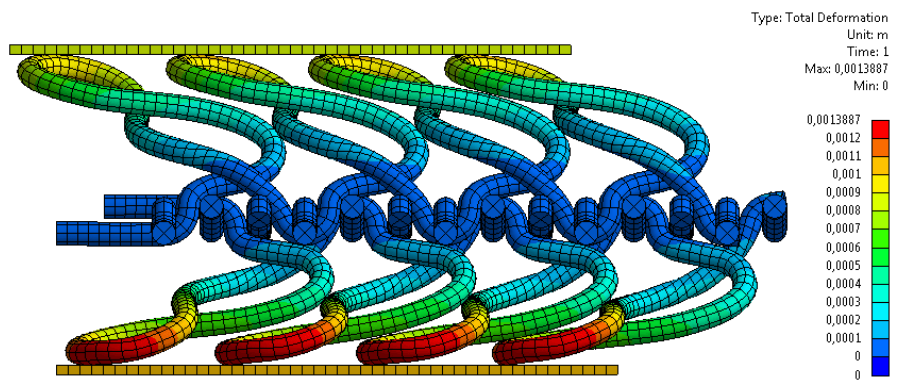

b) Deformation at maximum load

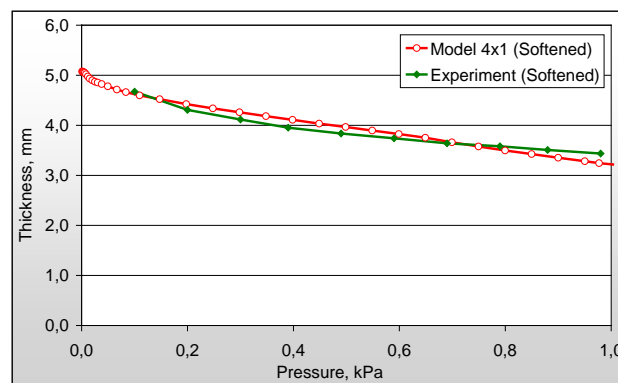

c) Comparing the simulation and the experimental deformation curve

Fig. 21 Model with 4x1 repeats

VI. CONCLUSIONS

The studies show that the successful computer simulation of terry fabric behaviour requires a *proper combination of the following factors*:

- 1) pile geometry – shape, overall dimensions and length of the thread, which builds it;
- 2) configuration of the computing model;
- 3) appropriate initial and boundary conditions;
- 4) elastic modulus of the cotton yarns.

The pile shape and the pile thread length in the repeat define the moments, in which it comes in contact with itself and with the adjacent piles. The insufficiently twisted pile untwists at deformation and do not make contact with itself, which does not correspond to the actual behaviour. If the pile is modelled with a smaller than the actual width, it comes into contact with the adjacent ones much later, which also does not correspond to reality. The slope of the piles, which also determines the time and the way in which they interact, is also of importance for the deformational behaviour.

The pile height determines the thickness of the non-deformed fabric and is of great importance for the simulation results at small and medium load levels. At high loads this parameter has little impact on the fabric behaviour, provided that the thread length in the repeat is the same.

The number of repeats in the computing model ($x \times y$) is very important, as the behaviour of the external piles differs from that of the internal ones. The degree of this influence is determined also by the pile shape. For example, for washed fabric the difference in the results of 3×3 and 2×2 is negligible. For the softened fabric, however, the difference in the results of 2×2 and 4×1 is significant. There should be an optimum number of repeats ensuring good accuracy, without incurring a significant increase in the time needed for simulation calculations.

The elasticity modulus E of cotton is the basic material constant, determining the fabric behaviour at deformation. To find its exact value, however, is not a simple task. In all cases it should be determined experimentally by measuring the real threads. The influence of the softeners and the other textile auxiliaries, used in the production, can be thus considered. Studies should focus on finding a complex evaluation of the elasticity modulus, including different types of loads, such as bending, tension, pressure, torsion etc. It would be, however, unrealistic to consider, that this would solve the problems with establishing the exact value. The presence of numerous assumptions, such as cylindrical shape of the thread, section density, absence of hairiness, uniformity of the cross-section, inevitably leads to the need of correction coefficients introduction that should take into account the impact of these and other factors, which can not or could hardly be considered.

REFERENCES

- [1] Aleksandrov S., D. Germanova-Krasteva, G. Kandzhikova, "Investigation on the Influence of Softener Concentration on Terry Fabric's Bending Rigidity", UniTech 2010, Gabrovo, Book II, pp. 291-293.
- [2] Aleksandrov S., D. Germanova-Krasteva, G. Kandzhikova, "Research on the Softness and Sorption Changes by Softening of Terry Fabrics", International Scientific Conference of the Faculty of Machine and Power Engineering, Sozopol, Book II, 2011, pp. 131-137.
- [3] Boisse P., A. Gasser, G. Hivet, "Analysis of Fabric Tensile Behaviour: Determination of the Biaxial Tension-Strain Surfaces and Their Use in Forming Simulations", Composites: Part A, 2001, pp. 1395-1414.
- [4] Boisse P., K. Buet, A. Gasser, J. Launay, "Meso/Macro-Mechanical Behaviour of Textile Reinforcements for Thin Composites", Composites Science and Technology, Vol. 61, 2001, pp. 395-401.
- [5] Boisse P., M. Borr, K. Buet, A. Cherouat, "Finite Element Simulations of Textile Composite Forming Including the Biaxial Fabric Behaviour", Composites: Part B, Vol. 28B, 1997, pp. 453-464.
- [6] Boussu F., X. Legrand, S. Nauman, V. Koncar, "Geometrical Modeling of 3D Textile Composite Application to Warp Interlock Carbon Fabrics", 13-th European Conference on Composite Materials, Sweden, 2008.
- [7] Byrnes K. R., K. Price, E. Easter, L. Adler, "Today's Textiles – Buying Towel", University of Kentucky, 2005.
- [8] Provatidis Ch., S. Vassiliadis, E. Anastasiadou, "Contact mechanics in two-dimensional finite element modelling of fabrics", International Journal of Clothing Science and Technology, Vol. 17, Iss. 1, 2005, pp. 29-40.
- [9] Das A., V.K. Kothari, N. Vandana, "A Study on Frictional Characteristics of Woven Fabrics", AUTEX Research Journal, Vol. 5, No. 3, 2003, pp. 133-140.
- [10] Eischen J.W., S. Deng, T.G. Clapp, "Finite-Element Modeling and Control of Flexible Fabric Parts", IEEE Computer Graphics and Applications, Vol. 16, Iss. 5, 1996, pp. 71-80.
- [11] Elder H.M., S. Fisher, K. Armstrong, G. Hutchinson, "Fabric Softness, Handle and Compression", Journal of the Textile Institute, Vol. 75, Iss. 1, 1984, pp. 37-46.
- [12] Frontezak-Wasiak I., M. Snycerski, "Use Properties of Terry Woven Fabrics", Fibres & Textiles in Eastern Europe, Vol. 12, 2004, pp. 40-44.
- [13] Frydrych I., G. Dziworska, A. Cieslinska, "Mechanical Fabric Properties Influencing the Drape

and Handle”, International Journal of Clothing Science and Technology, Vol. 12, No. 3, 2000, pp. 171-183.

[14] Germanova-Krasteva D., “Investigation on the Influence of Main Structural Parameters on Terry Fabrics’ Touch”, Textile and Clothing, No. 6, 2009, pp. 2-8

[15] Germanova-Krasteva D., S. Aleksandrov, G. Kandzhikova, “Influence of Finishing on Terry Fabrics’ Touch”, Textile and Clothing, No. 4, 2010, pp. 94-99.

[16] Hausch F., „Textilweichmacher Gestern und Heute“, CHT R. Beitlich GmbH, 2002.

[17] Hearle J.W.S., M. Konopasek, A. Newton, “On Some General Features of a Computer Based System for Calculation of the Mechanics of Textile Structure”, Textile Research Journal, Vol. 42, No. 10, 1972, pp. 613-626.

[18] Hearle J.W.S., P. Potluri, V.S. Thammandra, “Modelling Fabric Mechanics”, Journal of the Textile Institute, Vol. 92, Iss. 3, 2001, pp. 53-69.

[19] Hivet G., P. Boisse, “Consistent 3D Geometrical Model of Fabric Elementary Cell. Application to a Meshing Preprocessor for 3D Finite Element Analysis”, Elsevier, 2005.

[20] Karahan M., R. Eren, H.R. Alpay, “An Investigation into the Parameters of Terry Fabrics Regarding the Production”, Fibres & Textiles in Eastern Europe, Vol. 13, No. 2, 2005, pp. 20-25.

[21] Koç E., B. Zervent, “An Experimental Approach on the Performance of Towels – Part I. Bending Resistance or Softness Analysis”, Fibres & Textiles in Eastern Europe, Vol. 14, No. 1, 2006, pp. 39-46.

[22] Matsudaira M., H. Qin, “Features and Mechanical Parameters of a Fabric's Compressional Property”, Journal of the Textile Institute, Vol. 86, Iss. 3, 1995, pp. 476-486.

[23] Meredith R., J.W.S. Hearle, “Physical Methods of Investigating Textiles”, Textile Book Publishers, Inc., 1959.

[24] Nikolov N., D. Germanova-Krasteva, G. Kandzhikova, “Computational Model for Softness Assessment of Pile Fabrics Applying the Finite Element Method”, International Scientific Conference of the Faculty of Machine and Power Engineering, Sozopol, Vol. II, 2011, pp. 168-174.

[25] Nikolov N., D. Germanova-Krasteva, G. Kandzhikova, “Development of a 3D Model of Terry Fabric”, International Journal of Clothing Science and Technology, Vol. 24, Iss. 4, 2012, pp. 237-250.

[26] Reumann R.D., „Prüfverfahren in der Textil- und Bekleidungstechnik“, Springer, 2000, pp. 190-198.

[27] Shahabi N.E., S. Saharkhiz, M.H. Varkiyani, “Effect of Fabric Structure and Weft Density on the Poisson's Ratio of Worsted Fabric”, Journal of Engineered Fibers and Fabrics, Vol. 8, Iss. 2, 2013, pp. 63-71.

[28] Valatkiene L., E. Strazdiene, “Investigation of Fabric Impact Behaviour and It's Relationships with Mechanical Parameters and Hand Evaluation”, Materials Science, Vol. 11, No. 3, 2005, pp. 278-282.

[29] Vandereurzen P., J. Ivens, I. Verpoest, “Mechanical Modelling of Solid Woven Fabric Composites, 3D Textile Reinforcements in Composite Materials”, Woodhead Publishing Ltd., Cambridge, 1999, pp. 67-99.

[30] Yilmaz N.D., N.B. Powell, “Turkish Towel's Place in the Global Market”, Journal of Textile and Apparel, Technology and Management, Vol. 5, Iss. 4, 2007, pp. 1-43.

[31] Zyschka R., “Textile Softeners and Their Tricky Application”, CHT R. Beitlich GmbH, 2001.