

Modelling of Step-Up DC Converter

Vladimir V. Dimitrov, Peter T. Goranov

In the current paper building on the sound theoretical foundation of state-space methods a model for the boost converter is presented. Replacing some elements in the ideal power convertor with their nonideal equivalent circuits results in a general vector nonlinear time-varying differential equation describing the circuit behavior. Averaging the equation for one time period of the control frequency approximates the equation with one that is time-invariant. Solving the obtained equation for a particular equilibrium point results in a general expression for steady-state behavior. Subsequent small-signal linearization around the steady-state transforms the model to a linear time-invariant system (LTI). Using Laplace transform of the LTI system results in input-to-output and duty cycle-to-output transfer functions. The results for steady-state and small-signal dynamic modelling are plotted and some comments are made about optimum converter behavior.

Моделиране на процесите в транзисторен повишаващ преобразувател на постоянно напрежение (Владимир Димитров, Петър Горанов). В статията е разгледан обобщен математически анализ на повишаващ преобразувател отчитайки реални заместващи схеми на всеки от елементите в идеалната схема. Записаните в стандартна форма на променливи на състояние нелинейни диференциални уравнения, зависещи от времето, са усреднени за един период на управляващата честота, като апроксимацията позволява да се разгледат усреднени нелинейни уравнения, описващи процесите в схемата. На тяхна база е получен израз за предавателната функция в установен режим на преобразувателя. Следващата стъпка е линеаризация около този режим, което позволява получаване на изрази за предавателни функции на преобразувателя съответно между изхода и смущаващо въздействие или сигнал за управление. Така получените резултати са показани графично, и са дискутирани някои следствия от получената им форма.

Notation

$$x = \begin{bmatrix} i_L \\ v_C \end{bmatrix} \text{ State-space vector}$$

$$y = [u_o] \text{ Output vector}$$

I. Introduction

The boost converter is used in a wide range of applications ranging from emulating active load in power factor corrected power supplies to an intermediate power conditioning circuit in hybrid electric vehicles. This wide range of applications means a lot of design effort is required in achieving optimal steady state and dynamic characteristics, while accounting for different real parameters in the power circuit.

The goal of this paper is to obtain expressions describing the influence of nonideal circuit parameters on steady-state and dynamic behavior around it of the boost converter. Achieving the goal is made through state-space modeling of the dc-dc converter.

Replacing every component with its equivalent circuit will result in a very complicated model, so a simplification is made with accounting only for some the components – the internal resistance of the source voltage, channel resistance of the MOSFET, equivalent series resistance (ESR) of the output capacitor and diode resistance. It must be noted that the resistance of the connecting wires can be lumped in with some of the above, and will not be shown explicitly.

Experimental results show that the boost converter cannot achieve arbitrary large boosting of the input voltage, and in addition trying to increase the duty cycle boosts the input voltage only to a certain point, after which the output voltage starts rapid decreasing to zero.

The situation is described in figure 1. Increasing the duty-cycle (d) leads to higher output voltage (U_o), which leads to increased output current (I_o), meaning also higher current consumed from the source (I_s). In a real circuit this will lead to higher voltage drop in the resistance between the source and the converter, resulting in lower input voltage U_d for the power circuit. In most cases the power circuit is part of an automatic control system, which

stabilizes some load parameters (usually the output voltage). Then the control system increases the duty cycle in an attempt to compensate for the lower input voltage.

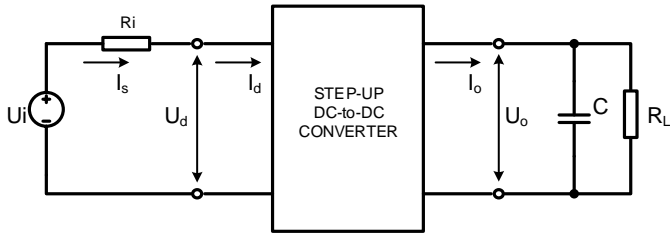

figure 1 Block diagram

However, it can happen that for a particular value of the parameters involved increasing d , respectively U_o , I_o and I_s , cannot compensate for the voltage drop. This is an undesirable situation because in an attempt to stabilize output voltage the controller increases the duty cycle d to the maximum possible ($d=d_{max}$, for example. 95%). Usually this results in nearly short circuit at the input of the converter, and significant reduction of output voltage. Additionally, the converter is usually designed to work in steady state with a fixed value for the duty cycle that is smaller than the maximum achievable. In this case if the above described situation arises the magnetic material in the input inductor can saturate resulting in an almost short circuit for the source voltage. The situation persists until the load is removed or protection circuitry activates switching off the transistor.

The above described problems can be made concrete, so in the Section II expressions are obtained describing the influence of nonideal circuit parameters on steady-state and dynamic behavior around it of the boost converter. Subsequently the obtained results are plotted in Section III, and in Section IV a discussion is made about the influence that the individual parameters can have in the steady state and dynamic response of the converter. Finally, in Section V some comments are made about possible ramifications of the performed analysis.

II. Analysis

The analysis of the boost converter shown in figure 2 is based on the following assumptions:

1. the source voltage is $U_i = const$;
2. the input voltage source is real with input impedance R_i ;
3. the power MOSFET and diode are modelled with resistance in their on state R_T and R_D ;
4. the load impedance is modelled with R_L ;
5. the output capacitor is modelled with its capacitance C and equivalent series resistance (ESR) $R_{esr} = const$;
6. the converter is assumed to work in continuous conduction mode (CCM).

II.1 General State-Space Model

The purpose of the analysis is to find a connection between the output voltage and the duty cycle and input voltage in order to maintain the proper mode of operation.

The first step in the analysis is to transform the differential equation describing the behavior of the converter in every topological state in state-space form. Choosing the inductor current and capacitor voltage as the state variables the first order differential equation is:

$$(1) \frac{dx}{dt} = Ax + Bu$$

$$(2) y = Cx + Du$$

The step-up converter circuit and two equivalent circuits for CCM – when the transistor is on and off and are shown in figure 2.

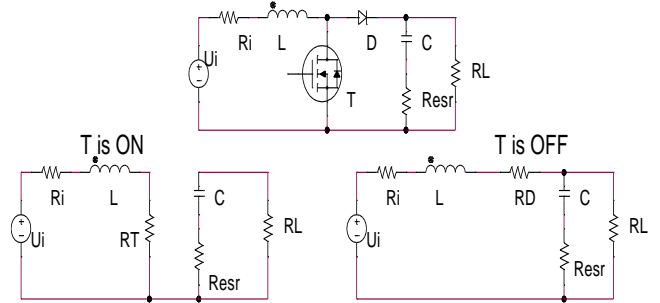

figure 2 Equivalent Circuits

When the transistor is on the equations are:

$$(3) \frac{di_L}{dt} = \frac{U_i - i_L(R_i + R_T)}{L}$$

$$(4) \frac{du_C}{dt} = \frac{-U_C}{C(R_{esr} + R_L)}$$

$$(5) u_o = \frac{u_C R_L}{R_{esr} + R_L}$$

When the transistor is off using the superposition principle for Linear Time Invariant (LTI) systems results in the following differential equations for the state variables:

$$(6) \frac{di_L}{dt} = \frac{u_i - i_L \left(R_i + R_D + \frac{R_{esr} R_L}{R_{esr} + R_L} \right) - u_C \frac{R_L}{R_{esr} + R_L}}{L}$$

$$(7) \frac{du_C}{dt} = \frac{i_L R_L}{C(R_{esr} + R_L)} - \frac{u_C}{C(R_{esr} + R_L)}$$

$$(8) u_o = \frac{i_L R_L R_{esr}}{(R_{esr} + R_L)} + \frac{u_C R_L}{R_{esr} + R_L}$$

Converting (3), (4), (5), (6) (7) and (8) in state-space

form given in (1) and (2) the separate matrices are:

-When the transistor is on

$$(9) A_1 = \begin{bmatrix} \frac{-(R_i + R_T)}{L} & 0 \\ 0 & \frac{-1}{C(R_C + R_L)} \end{bmatrix}$$

$$B_1 = \begin{bmatrix} 1/L \\ 0 \end{bmatrix}, C_1 = \begin{bmatrix} 0 & R_L \\ R_L + R_C & 0 \end{bmatrix}, D_1 = \begin{bmatrix} 0 \\ 0 \end{bmatrix},$$

-when the transistor is off:

$$A_2 = \begin{bmatrix} \frac{-(R_i + R_D) - \left(\frac{R_C R_L}{R_C + R_L}\right)}{L} & 0 \\ \frac{R_L}{C(R_C + R_L)} & \frac{-1}{C(R_C + R_L)} \end{bmatrix}$$

$$B_2 = \begin{bmatrix} 1/L \\ 0 \end{bmatrix}, C_1 = \begin{bmatrix} R_L & R_L \\ R_L + R_C & R_L + R_C \end{bmatrix}, D_2 = \begin{bmatrix} 0 \\ 0 \end{bmatrix},$$

II.1 Approximate average model

Averaging the two topological states allows for a single differential equation description of the power conversion process. In this case the averaged matrices are:

$$(10) A_{av}(d) = dA_1 + (1-d)A_2$$

$$(11) B_{av}(d) = dB_1 + (1-d)B_2$$

$$(12) C_{av}(d) = dC_1 + (1-d)C_2$$

The single differential equation valid for the whole switching cycle is :

$$(13) \frac{dx}{dt} = A_{av}x + B_{av}u$$

$$(14) y = C_{av}x$$

This nonlinear differential equation must be linearized around an equilibrium solution to acquire the separate small-signal transfer functions describing the dynamic behavior of the converter. Assuming small perturbations around the equilibrium point allows neglecting higher order terms in its Taylor series:

$$(15) \frac{d(X(t) + \tilde{x}(t))}{dt} = A_{av}(D(t) + \tilde{d}(t)) [X(t) + \tilde{x}(t)] + B_{av}(D(t) + \tilde{d}(t)) [U(t) + \tilde{u}(t)] = A_{av}(D)X + B_{av}(D)U + A_{av}(d)|_{x=X, d=D} \tilde{x}(t) + B_{av}(d)|_{x=X, d=D} \tilde{u}(t) + \frac{\partial(A_{av}(d)x + B_{av}(d)u)}{\partial d} \Big|_{x=X, d=D} \tilde{d}(t)$$

$$(16) Y + \tilde{y}(t) = C_{av}(D(t) + \tilde{d}(t)) [X(t) + \tilde{x}(t)] = C_{av}(D)X + \frac{\partial(C_{av}(d)x)}{\partial d} \Big|_{x=X, d=D} \tilde{d}(t) + C_{av}(d)|_{x=X, d=D} \tilde{x}(t)$$

II.2 Dc Transfer Function

For the DC transfer function of the converter the derivative in (13) is set to zero and the following equations are obtained:

$$(17) X = -A_{av}^{-1}(D)B_{av}(D)U$$

$$(18) Y = C(D)X$$

Substituting from (9) and putting $\omega_0^2 = \frac{1}{LC}$,

$$R_{Leq} = \frac{R_L}{R_L + R_{esr}}, R_{on} = R_T, R_{off} = R_D + R_{Leq}R_{esr}$$

the following expression is obtained for the DC transfer function:

$$(19) \frac{U_{out}}{U_{in}} = -C_{av}A_{av}^{-1}B_{av} =$$

$$\frac{\frac{R_{Leq}^2 R_{esr} (1-D)}{R_L} + R_{Leq}^2 (1-D)}{\frac{R_{Leq}}{R_L} (R_i + R_{on}D + R_{off}(1-D)) + R_{Leq}^2 (1-D)^2} = \frac{R_L (1-D)}{R_i + R_{on}D + R_{off}(1-D) + \frac{R_L^2}{R_L + R_{esr}} (1-D)^2}$$

To obtain the maximum achievable boosting of the input voltage the derivative with respect to the duty cycle is first obtained:

$$(20) \frac{\partial U_{out}/\partial d}{U_{in}} = \frac{n}{d}$$

$$n = -\left(\frac{R_i}{R_L} \frac{1}{(1-D)^2} + \frac{R_{on}}{R_L} \left(\frac{1}{(1-D)} + \frac{D}{(1-D)^2} \right) - \frac{R_L}{R_L + R_{esr}} \right)$$

$$d = \left(\frac{R_i}{R_L} \frac{1}{(1-D)} + \frac{R_{on}}{R_L} \frac{D}{(1-D)} + \frac{R_{off}}{R_L} + \frac{R_L}{R_L + R_{esr}} (1-D) \right)^2$$

Setting to zero the numerator in (20) the following expressions are obtained:

$$(21) \frac{-\left(\frac{R_i}{R_L} + \frac{R_{on}}{R_L} \right) + \frac{R_L}{R_L + R_{esr}} (1-D_{max})^2}{(1-D_{max})^2} = 0$$

$$(1-D_{max})^2 = -\frac{\left(\frac{R_i}{R_L} + \frac{R_{on}}{R_L} \right)}{\frac{R_L}{R_L + R_{esr}}}$$

$$D_{max} = 1 \pm \frac{\sqrt{(R_i + R_{on})(R_{esr} + R_L)}}{R_L}$$

The duty cycle is less than one so only the negative square root is kept:

$$(22) D_{max} = 1 - \frac{\sqrt{(R_i + R_{on})(R_{esr} + R_L)}}{R_L}$$

Lastly the duty cycle in (22) is substituted in the expression for the DC Transfer function:

$$(23) \frac{U_o}{U_{i_{max}}} = \frac{\sqrt{(R_i + R_{on})(R_{esr} + R_L)}}{2R_i + R_{on} \left(2 - \frac{\sqrt{(R_i + R_{on})(R_{esr} + R_L)}}{R_L} \right) + \frac{R_{off}}{R_L} \sqrt{(R_i + R_{on})(R_{esr} + R_L)}}$$

Assuming that the output capacitor has small equivalent series resistance in comparison with the load resistance, which is reasonable for most power levels, the formula for the maximum achievable duty cycle can be approximated with:

$$(24) D_{max} = 1 - \sqrt{\frac{(R_i + R_{on})}{R_L}}$$

II.3 Dynamic Transfer Functions

II.3.1 Input-to-Output Transfer Function

The next phase of the analysis is to obtain expressions for the small signal dynamics of the converter. Separating the small perturbations around the steady-state value a differential equations is obtained for them:

$$(25) \frac{d\tilde{x}}{dt} = A_{av}(D)\tilde{x} + B_{av}(D)\tilde{u} + [(A_1 - A_2)X + (B_1 - B_2)U]\tilde{d}$$

$$(26) \tilde{y} = C_{av}(D)\tilde{x} + [(C_1 - C_2)X]\tilde{d}$$

The input-to-output and duty cycle-to-output transfer functions are obtained by Laplace transforming the equation with zero initial conditions, and considering only one input at a time.

The input-to-output transfer function is:

$$(27) \frac{\tilde{y}(p)}{\tilde{u}(p)} = C_{av}(D)(sI - A_{av}(D))^{-1} B_{av}(D)$$

Substituting the individual matrices from (9) the following expression are obtained:

$$(28) (pI - A_{av})^{-1} = \frac{\begin{bmatrix} p + \frac{R_{Leq}}{R_L C} & -\frac{R_{Leq}(1-D)}{L} \\ \frac{R_{Leq}(1-D)}{C} & p + \frac{R_i + R_{on}D + R_{off}(1-D)}{L} \end{bmatrix}}{\det(pI - A_{av})}$$

$$\det((pI - A_{av})) = p^2 + p \left(\frac{R_{Leq}}{R_L C} + \frac{R_i + R_{on}D + R_{off}(1-D)}{L} \right) + \omega_0^2 \left(\frac{R_{Leq}}{R_L} (R_i + R_{on}D + R_{off}(1-D)) + R_{Leq}^2 (1-D)^2 \right)$$

$$(pI - A_{av})^{-1} B_{av} = \frac{1}{\det(pI - A_{av})} \begin{bmatrix} \frac{p}{L} + \omega_0^2 \frac{R_{Leq}}{R_L} \\ \omega_0^2 R_{Leq} (1-D) \end{bmatrix}$$

After some simplifications the final form of the transfer function is:

$$(29) \frac{\tilde{y}(p)}{\tilde{u}(p)} = C_{av} (pI - A_{av})^{-1} B_{av} = \frac{\frac{pR_{esr}R_{Leq}(1-D)}{L} + \frac{R_{Leq}^2\omega_0^2R_{esr}(1-D)}{R_L} + \omega_0^2R_{Leq}^2(1-D)}{\det(pI - A_{av})} = \frac{R_{esr}R_{Leq}(1-D)}{L} \frac{p + \omega_0^2LR_{Leq}\left(\frac{1}{R_L} + \frac{1}{R_{esr}}\right)}{\det(pI - A_{av})} = \frac{R_{esr}R_{Leq}(1-D)}{L} \frac{p + \frac{1}{CR_{esr}}}{\det(pI - A_{av})}$$

II.3.2 Duty cycle-to-Output Transfer Function

The duty cycle-to-output transfer function is obtained form :

$$(30) \frac{\tilde{y}(p)}{\tilde{d}(p)} = \left[C_{av}(D)(sI - A_{av}(D))^{-1} Q \right] + (C_1 - C_2)X$$

$$Q = (A_1 - A_2)X + (B_1 - B_2)U$$

The individual matrices are:

$$(31) Q = \begin{bmatrix} -\frac{R_{on} - R_{off}}{L} & \frac{R_{Leq}}{L} \\ -\frac{R_{Leq}}{C} & 0 \end{bmatrix} (-A_{av}^{-1} B_{av} U_{in})$$

$$(C_1 - C_2)X = \frac{-R_{esr} R_{Leq}}{\det(A_{av})} U_{in}$$

$$C_{av}(pI - A_{av})^{-1} Q + (C_1 - C_2)X = \frac{U_{in}}{\det(pI - A_{av}) \det(A_{av})} \left(-p^2 - pI_1 + I_2 \right)$$

$$I_1 = \frac{R_{Leq}}{R_L C} + \frac{R_i + R_{on} D + R_{off}(1-D)}{L} + \frac{R_{Leq}}{C R_{esr}} - \frac{1-D}{L} (-R_{on} + R_{off} + R_L R_{Leq}(1-D)) = \frac{1}{C R_{esr}} + \frac{1}{L} \left(R_i + R_{on} D + R_{off}(1-D) - (1-D) [-R_{on} + R_{off} + R_L R_{Leq}(1-D)] \right) = \frac{1}{C R_{esr}} + \frac{1}{L} (R_i + R_{on} - R_L R_{Leq}(1-D)^2)$$

$$I_2 = \left((1-D) \omega_0^2 \right) \left(-R_{on} + R_{off} + R_L R_{Leq}(1-D) \right) \frac{R_{Leq}}{R_L} + \omega_0^2 R_{Leq}^2 (1-D)^2 + \frac{\omega_0^2 R_{Leq}(1-D)}{R_{esr}} \left(-R_{on} + R_{off} + R_L R_{Leq}(1-D) \right) - \frac{R_{Leq}}{R_{esr}} \left(\frac{R_i + R_{on} D + R_{off}(1-D)}{L} \right) - \omega_0^2 \frac{R_{Leq}}{R_L} \left(\frac{R_i + R_{on} D}{+ R_{off}(1-D) + R_{Leq} R_L (1-D)^2} \right) =$$

$$= \left(\begin{matrix} -R_{on} + R_{off} \\ + R_L R_{Leq}(1-D) \end{matrix} \right) \omega_0^2 (1-D) R_{Leq} \left(\frac{1}{R_L} + \frac{1}{R_{esr}} \right) - \left(R_i + R_{on} D + R_{off}(1-D) \right) \omega_0^2 R_{Leq} \left(\frac{1}{R_L} + \frac{1}{R_{esr}} \right) = \frac{\omega_0^2}{R_{esr}} \left(\left[-R_{on} + R_{off} + R_L R_{Leq}(1-D) \right] (1-D) - \left(R_i + R_{on} D + R_{off}(1-D) \right) \right) = \frac{\omega_0^2}{R_{esr}} \left(-R_{on} - R_i + R_L R_{Leq}(1-D)^2 \right)$$

Substituting and simplifying the matrices (31) in (30) results in the following expression for the duty cycle-to-output transfer function :

$$\frac{\tilde{y}}{\tilde{d}} = \frac{U_{in} \left(\begin{matrix} -p^2 - p \left(\frac{1}{C R_{esr}} + \frac{1}{L} \left(R_i + R_{on} - R_L R_{Leq}(1-D)^2 \right) \right) \\ - \frac{\omega_0^2}{R_{esr}} \left(-R_{on} - R_i + R_L R_{Leq}(1-D)^2 \right) \end{matrix} \right)}{\det(pI - A_{av}) \det(A_{av})}$$

III. Results

III.1 Steady-State

In the last section a general formula for steady state behavior of the boost converter was derived. The plot of the function is shown in figure 3. For ease of plotting the dimensionless groups $\frac{R_i}{R_L} = \frac{R_T}{R_L} = \frac{R_{esr}}{R_L} = \frac{R_D}{R_L}$ are assumed equal.

The maximum achievable boosting of the input voltage obtained in (23) as a function of the above mention dimensionless groups is shown in figure 4.

III.2 Transfer functions

Using a step input and inverse Laplace transform the unit step responses from input-to-output and duty cycle-to-output are shown in figure 5 and figure 6 for two different steady state points.

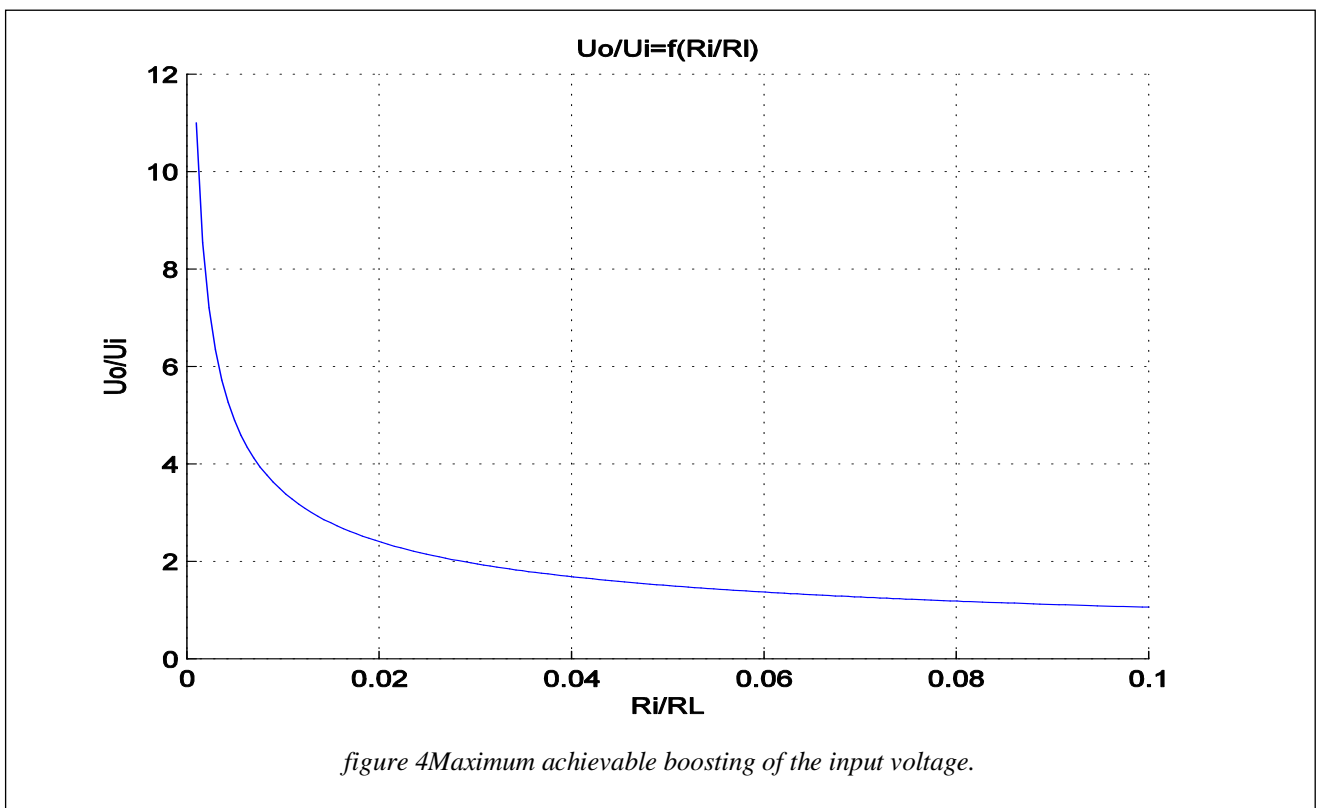
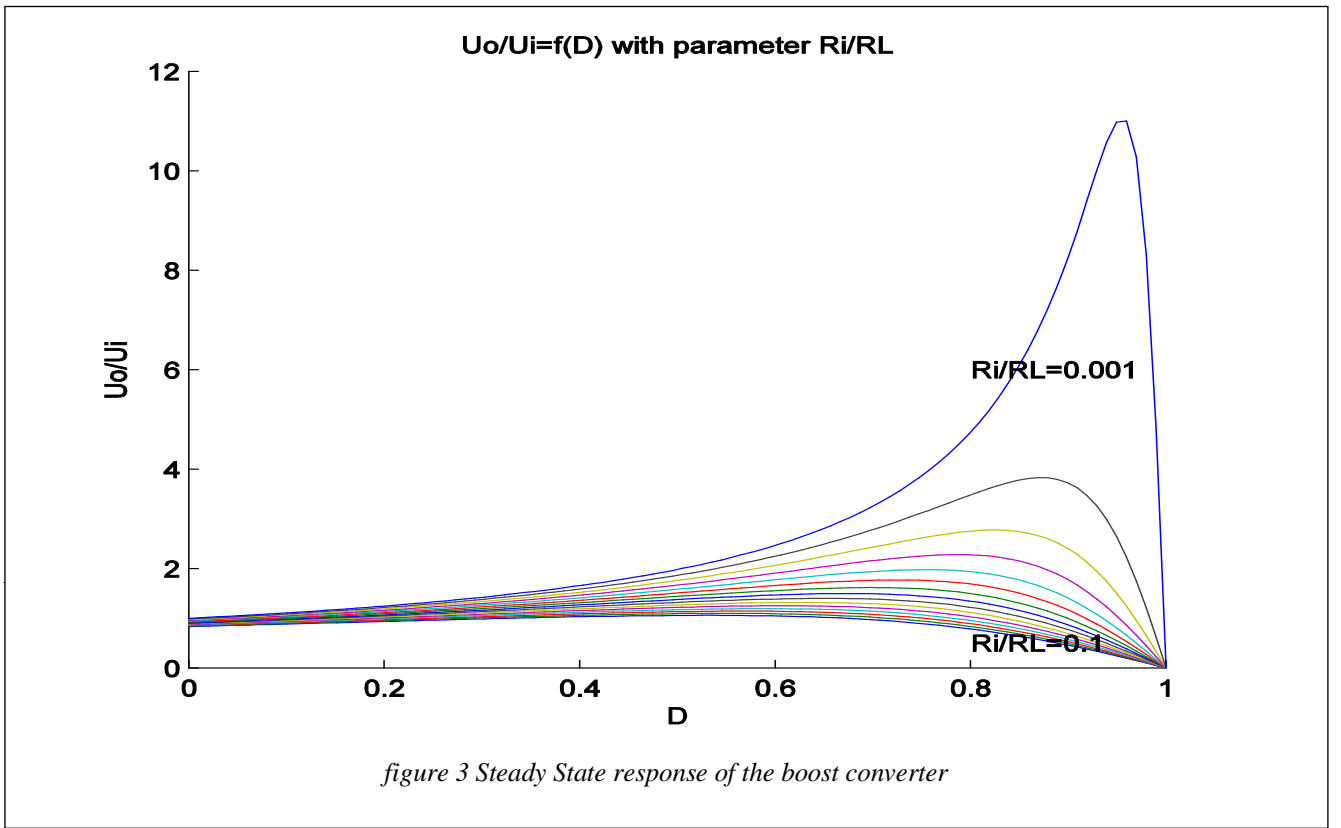

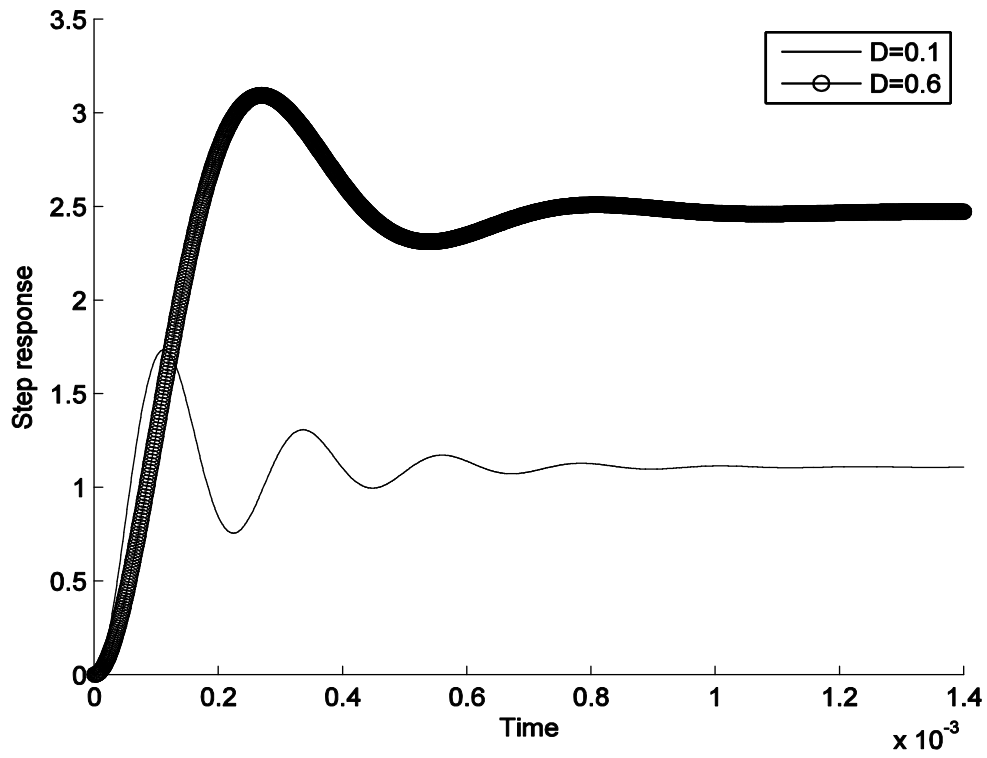

figure 5 Input-to-Output step response

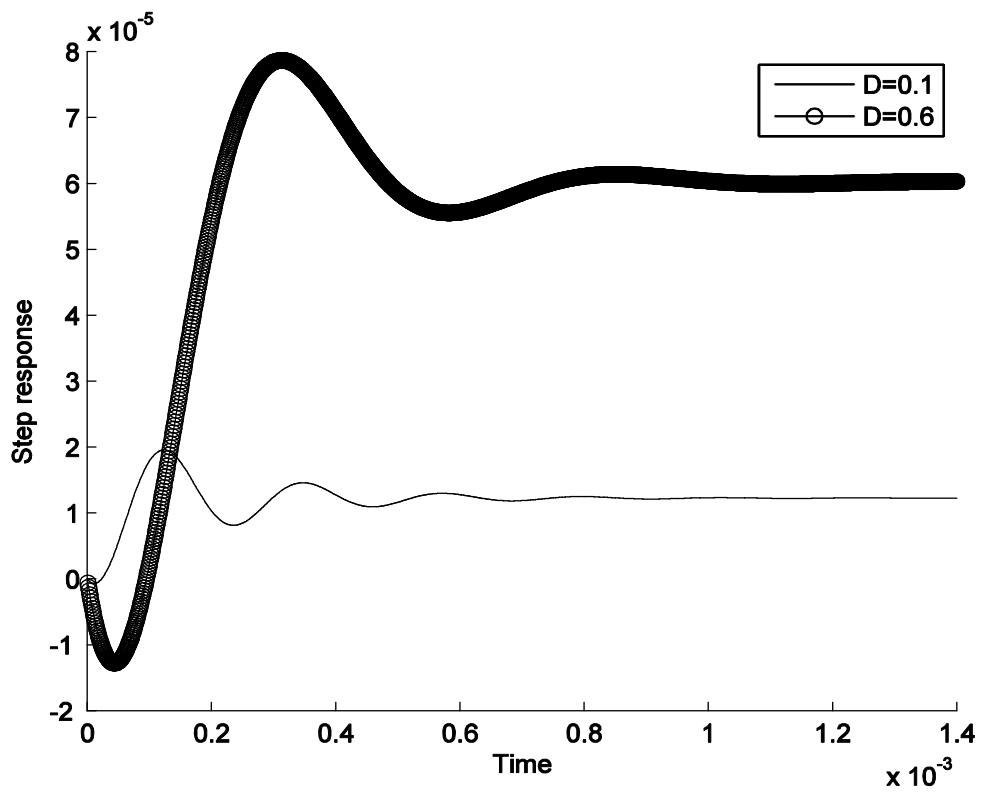

figure 6 Duty Cycle-to-Output step response

IV. Discussion

IV.1 Steady-State

The plotted graph of the steady state response of the boost converter shows that it cannot achieve arbitrary high output voltages. The maximum achievable boosting of the input voltage can be obtained in (23) shows that the most contributing parasitic resistances to the observed gain fall-off are the ones from the source and transistor. This makes sense because high values of boosting require greater quantities of energy to be stored in the magnetic field of the inductor during the transistor on time, and the presence of the source and transistor resistances impedes it.

IV.2 Transfer Functions

The forms of the input-to-output transfer function show that it is of second order (two poles) with no zeros. This permits the use of well-known approximated expressions between time domain and frequency domain parameters.

On the other hand, the duty cycle-to-output transfer function although it is of second order it has a right hand zeros that depend on several different time constants. This makes the overall transfer function a non-minimal phase complicating its compensation in a closed loop system.

The non-minimal phase transfer function between the duty cycle and output can be explained on physical grounds in the following way: During steady state operation of the converter if the input voltage sinks from U_1 to U_2 ($U_2 > U_1$), the control system will react rising the duty cycle from D_1 to D_2 ($D_2 > D_1$) in order to keep the output voltage constant. But during the time the transistor is on the output voltage is kept constant only by the output capacitor, so in a dynamic situation raising the duty-cycle will result in a longer on time of the transistor. During this period the load will have more time to discharge the output capacitor resulting in lower output voltage.

One solution to the non-minimal phase control problem is to use full state feedback control system instead measuring only the output voltage and comparing it to the reference voltage. This leads to the natural distinction between current mode (full state feedback) and voltage mode control.

V. Conclusion

In this paper formulas for the DC transfer function and small signal input-to-output and duty cycle-to-output of a boost converter operating in CCM are derived. These form the base on which the behavior of the converter in transient and steady state is analyzed as a function of different parasitic resistances.

The underlying approximation allowing the small signal transfer functions doesn't allow their use in analysis of the start-up transient of the converter. However, they can be used as an initial guess of its closed loop start-up transient with increasing the calculated overshoot.

Although the paper concerns itself only with the boost converter operating in CCM, and only deriving two of the five transfer functions, similar analyses can be made for other dc-to-dc converters using the same steps, as only in this class of power electronic converters the resulting expressions are LTI allowing more practical analysis.

VI. References

- [1] Kassakian, J., Schlecht, M., & Verghese, G. (1991). *Principles of Power Electronics*. Addison-Wesley.
- [2] Maksimovic, D., Stanković, A., Thottuvelil, V., & Verghese, G. C. (Jun 2001). Modeling and simulation of power electronic converters. *Proceedings of the IEEE*, vol.89, no.6, pp.898,912.
- [3] Middlebrook, R. (1988). Small-signal modeling of pulse-width modulated switched-mode power converters. *Proceedings of the IEEE*, 343,354.
- [4] Middlebrook, R., & Cuk, S. (1976). A General Unified Approach to modeling switching-converter power stages. *PESC*. IEEE.
- [5] Ogata, K. (2010). *Modern Control Engineering*. Prentice Hall.
- [6] Vorperian, V. (1990). Simplified analysis of PWM converters using model of PWM switch. Continuous conduction mode. *Aerospace and Electronic Systems, IEEE Transactions on*, 490-496.

Assoc. Prof. Peter Goranov is a PhD in Power Electronics, lecturer at Power Electronics Department, TU-Sofia. Research interests are in the field of power electronics circuit analyze, design and applications, their control systems.

tel.:+359888953048 e-mail: pgoranov@ecad.tu-sofia.bg

Eng. Vladimir Dimitrov is currently pursuing a PhD degree in Power Electronics at Technical University in Sofia. Current research interests include control of power electronic converters, power electronics applications in electric and hybrid electric vehicles.

tel.:+359886341420 e-mail: vdimitrov88@gmail.com
