

Antenna Diversity Multi User Detection Algorithm for Synchronous CDMA System

Ilia Georgiev Iliev¹

Marin Nedelchev²

Abstract – A spatial diversity reception assisted multiuser code-division multiple-access detector based on consecutively search algorithm is proposed. Algorithm performances and the precision are theoretical studied. Functional dependence between number of the iterations and error rate performance are derived. Computer simulations show high computational speed and acceptable BER precision of the algorithm. For 10 users and spreading factor 31 a computational complexity is reduced 85 times in comparison with the optimum multiuser detector using full search.

Keywords – MUD, CDMA, Antenna Diversity, DS.

I. INTRODUCTION

Main problem of the CDMA systems is the Multiple Access Interference – MAI, caused by the distortion of the orthogonality of the signals by every one user. The presence of MAI reduces the signal-to-interference ratio and therefore decreases the noise performance of the mobile communication system. As it is well known, from the loss of information point of view, the correlation receiver is optimal when MAI is missing. There exist multiple of methods for reduction of MAI, but one of most effective is the parallel multiuser detection [1]. The optimal receiver for parallel multiuser detection (MUD) is based on the maximum likelihood criterion (ML) [1].

Finding of the optimal decision is connected with checking of all possible combinations of the transmitted symbols. Consequently the huge number of calculations is a drawback of the ML MUD. They increase exponentially with the active users. This seriously makes difficult its application in the conventional mobile communication systems, despite of the high computational power of the current DSPs.

There are multiple suggestions, in the literature, of methods and algorithms for suboptimal receiving that decrease the computational complexity for detection. In most of the cases they are a trade-off between the computational complexity and the quality factors of the receiver [2,3]. There are suggestions for MUD involving parametric optimization. The maximum a posteriori probability (MAP) [1] is used as a cost function for optimization. In the case of MUD the cost function is discrete, intermittent, non-differential, non-unimodal. Therefore it is appropriate to use the methods for random search, genetic algorithm, evolutionary strategy etc [4,5,6]. Their application reduces the number of calculations

in comparison to the optimal receiver with ML for MUD.

The paper investigates the algorithm possibilities for MUD that uses discrete consecutive search. The starting point for optimization is found by correlative reception. The algorithm accuracy and its computational speed are bettered, if antenna diversity with maximum ration combining is used.

II. OPTIMAL MUD IN SYNCHRONOUS CDMA SYSTEM

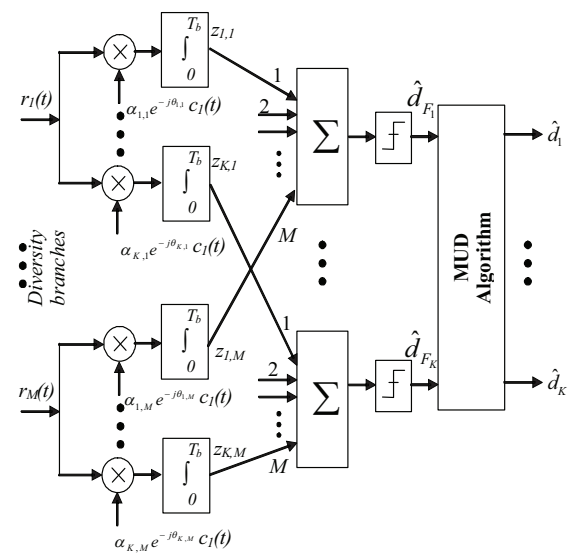

Fig.1

The block schematic of the system is shown on Fig.1. The processing is in baseband and consists of M number of receivers for special diversity. It is supposed that the diversity makes the signals from different receivers are statistically independent. K users transmit synchronously signals with direct spread spectrum (DSS) and 2PSK modulation. Every branch is a correlation receiver with output the received vector z , with elements:

$$z_m = [z_1, z_2, \dots, z_K]^T = \mathbf{R} \mathbf{A}_m \mathbf{E} \mathbf{d} + \mathbf{n}_m \quad (1),$$

where m is the receiver $m=1..M$, $\mathbf{d} = [d_1, d_2, \dots, d_K]^T$ is a vector column that consists the value of the transmitted symbol with duration T_b coming from the k user. The symbols are presented in binary code $d_k \in \{-1, +1\}$. \mathbf{R} is the $K \times K$ cross correlation matrix, which coefficients are the values of the normalized cross correlation functions of the code sequences:

^{1,2} Ilia Georgiev Iliev and Marin Veselinov Nedelchev –are with Dept. of Radiocommunication and Videotechnologies in Faculty of Telecommunication in TU –Sofia, N8, Kliment Ohridski bul., 1700 Sofia, Bulgaria. E-mail: igiliev@tu-sofia.bg

$$R_{ij} = \frac{1}{N} \int_0^{T_b} c_i(t)c_j^*(t)dt \quad (2).$$

$n_m(t)$ is the realization of complex additive white Gaussian noise (AWGN) in the input of the m -th receiver with independent real and imaginary component and each of them has $\sigma^2 = N_o/2$ [W/Hz]. \mathbf{n}_m is a AWGN after the m -th correlator as a vector column $\mathbf{n}_m = [n_{1,m}, n_{2,m}, \dots, n_{K,m}]^T$ with covariance matrix equal to: $\mathbf{R}_n = 0.5N_o\mathbf{R}$. k -th element is:

$$n_{k,m} = \int_0^{T_b} n_m(t)c_k(t)dt.$$

$\mathbf{A}_m = \text{diag}[\alpha_{1,m}e^{j\theta_{1,m}}, \alpha_{2,m}e^{j\theta_{2,m}}, \dots, \alpha_{K,m}e^{j\theta_{K,m}}]$ is a diagonal matrix and the elements in the main diagonal are the complex transmission coefficients of the channel for each user in m -th channel. The channel is supposed to be with slow Raleigh fading. The amplitudes have Raleigh distribution; the phase difference distribution in the channel is uniform in the interval $[0, 2\pi]$. It is assumed that the channels for each user are statistically independent. $\mathbf{E} = \text{diag}[\sqrt{E_1}, \sqrt{E_2}, \dots, \sqrt{E_K}]$ is a diagonal matrix. $\sqrt{E_k}$ is the symbol energy for the k -th user, \mathbf{c} – is a matrix with rows the spreading sequence for each user and $c_k^{(n)} \in \{-1, +1\}$. The length of the sequences is equal to $N - N = T_b / T_c$, T_c is the element duration.

The optimal MUD is done, when the MAP criterion is applied [1]. The maximum of the correlation of the received signal with every one of the transmitted signals is searched for. The logarithmic function of likelihood for the m -th receiver is expressed in matrix form as:

$$\Psi_m(\mathbf{d}) = 2\Re(\mathbf{d}^T \mathbf{E} \mathbf{A}_m^* \mathbf{z}) - \mathbf{d}^T \mathbf{E} \mathbf{A}_m \mathbf{R} \mathbf{A}_m^* \mathbf{E} \mathbf{d} \quad (3).$$

The symbol $()^*$ denotes complex conjugate value, and $()^T$ – transposed matrix. The maximum ratio combining diversity (MCR) requires the decision for the transmitted symbols to be taken on the base of the quantity statistics:

$$\Psi(\mathbf{d}) = \sum_{m=1}^M \Psi_m(\mathbf{d}) \quad (4).$$

The decision for the transmitted symbols is:

$$\hat{\mathbf{d}} = \arg \left\{ \max_{\mathbf{d}} [\Psi(\mathbf{d})] \right\} \quad (5).$$

III. POSSIBILITIES OF THE ALGORITHM FOR SUBOPTIMAL RECEIVING WITH CONSECUTIVE SEARCH

A. Algorithm for consecutive search.

Finding of optimal decision in MUD is considered as an optimization problem using multiparameter discrete, non-unimodal cost function-(4). Because of the channels are

statistically independent $\Psi_i(\mathbf{d}) \neq \Psi_j(\mathbf{d})$ за $i \neq j$, $\Psi(\mathbf{d})$ is the multi criteria cost function. This paper proposes the use of algorithm for consecutive search, detailed and analyzed in [9]. The optimization parameters are elements of a vector with the symbols coming from the users \mathbf{d} . The output data from the correlation receivers, when hard decision is made, is:

$$\hat{\mathbf{d}}_{F_m} = [\hat{d}_{F_{1,m}}, \hat{d}_{F_{2,m}}, \dots, \hat{d}_{F_{K,m}}] = \text{sign} \{ \Re(\mathbf{A}_m^* \mathbf{z}) \} \quad (6).$$

The start point for optimization is determined after MCR:

$$\hat{\mathbf{d}}_F = \text{sign} \left\{ \sum_{m=1}^M \Re(\mathbf{A}_m^* \mathbf{z}) \right\} \quad (7).$$

If in the package \mathbf{d} has one error bit, then it may be corrected according to the decision criterion (5). It is necessary to do only $(K+1)$ computations of the cost function (4) with vectors from the set M_d that have Hemming distance with the vector $\hat{\mathbf{d}}_F$ unit:

$$M_d = \left\{ \mathbf{d} : H_d(\hat{\mathbf{d}}_F, \mathbf{d}) = 1 \right\} \quad (8).$$

One iteration of the algorithm is related to a search in the vicinity of a point in the K -dimensional space with Hemming distance unit. This is realized as for every one step of the optimization process consecutively changes one bit of the vector \mathbf{d} (it changes the value of the bit) and for every change computes the cost function. Then the algorithm chooses the maximum value of (6). The next vector for i -th iteration is:

$$\mathbf{d}^{(i+1)} = \arg \left\{ \max_{\mathbf{d} \in M_d} [\Psi(\mathbf{d}^{(i)})] \right\} \quad (9).$$

Searching for optimal decision is confined after satisfying at least of one of both criteria. The first confines the number of the iterations L and the second is:

$$\max_{\mathbf{d} \in M_d} [\Psi(\mathbf{d}^{(i+1)})] \leq \max_{\mathbf{d} \in M_d} [\Psi(\mathbf{d}^{(i)})] \quad (10).$$

The search for optimal decision is stopped unconditionally by the strong criterion (10). This reduces the number of computations of the cost function (4), but at the expense the accuracy of the algorithm.

B. Theoretical Algorithm Performance

The symbols in the output of the receiver are parallel and the received vector $\hat{\mathbf{d}}$ is a package consists of K number symbols. The user channels are independent. The error probability for the k -th bit when diversity reception and maximal combining ratio for Raleigh fading channel is:

$$Pe_{k_{MCI}} = \left(\frac{1-\mu}{2} \right)^M \sum_{m=0}^{M-1} \binom{M-1+m}{m} \left(\frac{1+\mu}{2} \right)^m \quad (11),$$

$$\mu = \sqrt{\frac{SINR}{1+SINR}} \text{ и } SINR = E_{b1} / \left(N_o + 2\sigma_R^2 \sum_{k=2}^K E_{bk} \right).$$

This formula is for single user detection and M branches for diversity. SNIR is the signal-to-noise plus interference ration. It is assumed that the MAI has Gaussian distribution with dispersion σ_R^2 . This is the dispersion of the values of the cross correlation functions. If it is used an algorithm for power equalization and management the SNIR is transformed into:

$$SINR = 1 / [N_o + (K - 1) / N].$$

Let the spreading sequences are random bipolar with uniform value distribution. The number of error symbols in a packet q has binomial distribution and the probability is determined by [9]:

$$P_K(q) = C_K^q (Pe_{kMAI})^q (1 - Pe_{kMAI})^{K-q} \quad (12).$$

Let assume that the cost function (4) decreases with increasing the Hemming distance to the optimal solution in (5). If errors in the package are more than one, this procedure can be repeated consecutively as many times as there are errors in the packet. Each iteration in the consecutive search reduces the number of errors in the package with one. This reduction of the error, the lower limit of the error probability for one bit, for one user could be determined by the formula:

$$P_e = \sum_{q=L+1}^K \frac{q-L}{K} C_K^q (Pe_{kMAI})^q (1 - Pe_{kMAI})^{K-q} \quad (13),$$

where L is the number of the iterations for consecutive search.

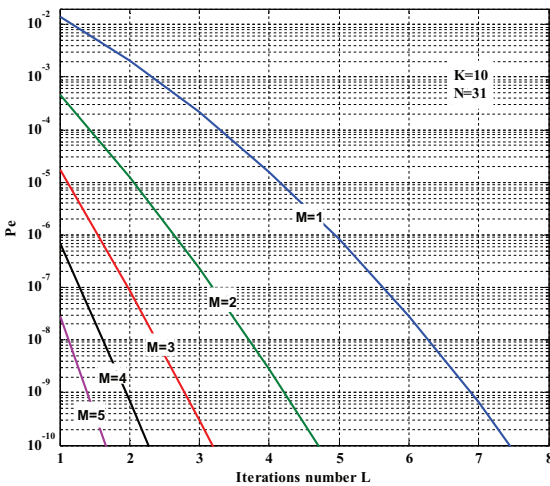

Fig.2

Fig.2 shows the dependence of the error probability against the number of iterations for different number of branches for diversity receiving M. The number of active user is K=10. Fig.3 shows the error probability for one bit in function of the active users when a parameter is M and a fixed number of iterations L=4. If M=5, it is seen that the algorithm accuracy is satisfactory from the practical point of view- $Pe < 10^{-6}$. The

results from both figures are derived when AWGN impact is neglected. It is seen from Fig.2 that the increase of M, the necessary iteration in the algorithm for achieving specified error probability reduces. The dependences from (13), Fig.2 and Fig.3 give possibilities for a specified error probability and specified number of active users to define the minimum number of iterations of the algorithm L. Then, adaptive changes the number of calculations depends on the load of the mobile networks. It is seen that the algorithm of the consecutive search reduces significantly the number of computations of the cost function- because of the strict criterions for detection stopping.

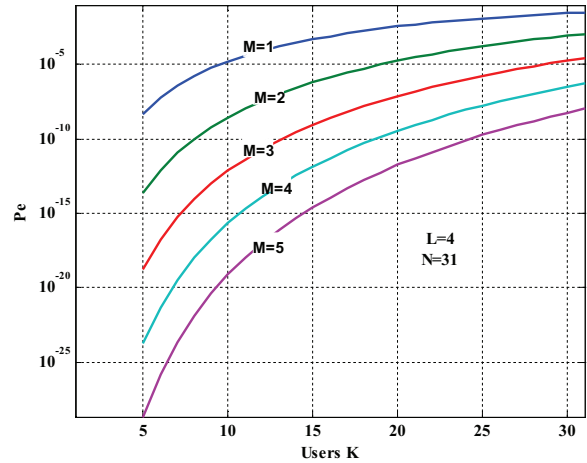

Fig.3

IV. SIMULATION RESULTS

The algorithm is simulated in MATLAB. The processing gain of the signature sequences is $N=31$, and the sequences are randomly generated. Perfect power control and CIR estimation is assumed. The channel is modelled as AWGN with slow Raleigh fading and $E[\alpha^2_{k,m}] = 1 \forall m, k$.

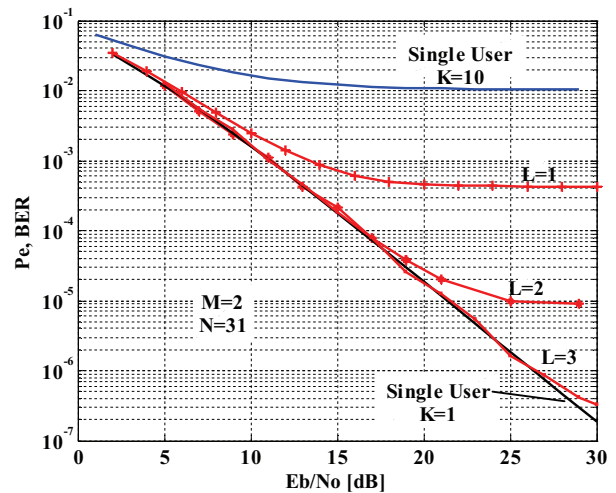

Fig.4

Fig.4 shows the measures BER against the average value of E_b/N_0 for $K=10$ and different number of $L=1,2,3 - M=2$. The results show that the increase of the number of iterations it approaches the theoretical curve for full compensation of MAI or single receiving for $K=1$. BER is limited from below and the value coincide with the one calculated with formula (13). The results show that the diversity receiving increases the speed of the algorithm, because the starting point is close to the minimum. The accuracy is bettered because the probability of “sticking” of the algorithm in a local minimum is low.

A. Computational complexity of the algorithm

In [8] is made a comparison of the computational complexity of some conventional algorithms for MUD – common correlation receiver, decorrelation receiver for MUD, optimal receiver for MUD [1] and MUD with genetic algorithm [8]. The computational complexity is determined on the base of the number of multiplications and sums for calculation of the likelihood logarithmic function (3) for detection of K bits. For the decorrelation receiver the computational complexity is proportional to $Q=K^3$. For the optimal algorithm the number of computations Q with the function (4) are $Q=2^K$. The computational complexity of the proposed algorithm is defined as the average number of computations of the cost function $\Psi(\mathbf{d})$.

For $K=10$ the Table 1 compare the computational number of fitness function (4) for proposed algorithm against specified conventional multiuser detectors.

TABLE 1

Decorrelator MUD $Q \sim K^3$	Optimum MUD $Q=2^K$	GA MUD [8] $Q=PY$	Proposed MUD (14) Q
1000	1024	300	12.3

The computational complexity of proposed algorithm is measured by simulation when the number of iterations are $L=3$. The results show that the proposed algorithm has tens or hundreds of times less computational complexity compared to the known detectors, when meeting the practical needs of decision accuracy.

V. CONCLUSION

The results show that the diversity reception helps in certain extent to improve the error performance in MUD. Thanks to its increased accuracy of detection due to reduction of the probability for “sticking” of the algorithm in a local minimum. Because of the independence of the channels, it is reduced the number of the necessary iterations of the algorithm, which is important in its practical application. As a result of the derived formulas in the paper, it is possible to determine the number of necessary iterations for a specified BER and number of active users. This allows flexible management and economical use of the computational resources. The simulation results show that the number of the computations for the proposed algorithm is ten times less than the known optimal and suboptimal detectors.

VI. REFERENCES

- [1] S. Verdú, Multiuser Detection. New York: Cambridge Univ. Press,1998.
- [2] R. Lupas and S. Verdú, “Linear multiuser detectors for synchronous code-division multiple-access channels,” IEEE Trans. Inform. Theory, vol. 35, pp. 123-136, Jan. 1989.
- [3] Z. Xie, R. Short, and C. Rushforth, “A family of suboptimum detectors for coherent multiuser communications,” IEEE Journal on Selected Areas in Communications, vol. 8, pp. 683-690, May 1990
- [4] C. Ergun and K. Hacioglu, “Multiuser detection using a genetic algorithm in CDMA communications systems,” IEEE Trans. Commun., vol. 48, pp. 1374–1383, Aug. 2000.
- [5] M. J. Juntti, T. Schlösser, and J. O. Lilleberg, “Genetic algorithms for multiuser detection in synchronous CDMA,” in IEEE International Symposium on Information Theory – ISIT’97, (Ulm, Germany), p. 492, 1997.
- [6] K. Yen and L. Hanzo, “Hybrid genetic algorithm based multi-user detection schemes for synchronous CDMA systems,” in Proceedings of the IEEE Vehicular Technology Conference (VTC), (Tokyo, Japan), May 15-18,2000.
- [7] Peng Hui Tan, Lars K. Rasmussen, Multiuser Detection in CDMA—A Comparison of Relaxations, Exact, and Heuristic Search Methods, IEEE TR. WIRELESS COMM., VOL. 3, N 5, SEPT. 2004
- [8] K. Yen and L. Hanzo, Antenna-Diversity-Assisted Genetic-Algorithm-Based Multiuser Detection Schemes for Synchronous CDMA Systems, IEEE TRANSACTIONS ON COMMUNICATIONS, VOL. 51, NO. 3, MARCH 2003
- [9] Ilija G.Iliev, Marin V. Nedelchev, Performance Analysis of a suboptimal multiuser detection algorithm, ICEST 2007, Macedonia, pp.531 – 534.