

Comparison of the piezoelectric properties of single-layer and bilayer structures with thin films of PZT and ZnO in dynamic mode

Yordanka Vucheva¹, Georgi Kolev¹, Mariya Aleksandrova¹ and Krassimir Denishev¹

Abstract – In this paper the piezoelectric effect was investigated for two types of samples, consisting of piezoelectric thin films PZT and ZnO with potential application as energy harvesting microdevice. The layers are deposited by RF sputtering on flexible polyethylene terephthalate (PET) substrates. Thermally evaporated aluminum (Al) films were used as bottom and top contacts. The piezoelectric reaction of the samples was measured by lab made experimental setup for dynamic mode. The generated piezoelectric charge was measured at different frequencies of the vibrations.

Keywords – PZT, ZnO, MEMS sensors, RF sputtering, piezoelectric thin films

I. INTRODUCTION

Piezoelectric effect is the ability of certain materials to generate an electric charge in response to applied mechanical stress. One of the unique characteristics of the piezoelectric effect is that it is reversible, meaning that materials exhibiting the direct piezoelectric effect (the generation of electricity when stress is applied) also exhibit the converse piezoelectric effect (the generation of stress when an electric field is applied) [1]. This effect is formed in crystals that have no center of symmetry. Such crystals are the piezoelectric materials lead zirconium titanate, known as PZT and zinc oxide (ZnO).

Piezoelectric materials, such as PZT and ZnO are very important for the Micro-electro-mechanical systems (MEMS) and Nano-electro-mechanical systems (NEMS) design, as sensors and actuators. Traditionally, the PZT and ZnO are used as bulk materials with thickness higher than 100-200 μm , which are difficult to be integrated into microdevices. The requirements for miniaturization can be fulfilled by conversion of the piezoelectric materials into thin nanometric films via conventional microelectronic technology, like RF sputtering.

ZnO forms a hexagonal wurtzite structure with 6mm symmetry. It possesses the lack of center symmetry required for piezoelectric materials. The coupling coefficient for ZnO is also relatively high which makes ZnO an excellent material to use in a wide variety of piezoelectric applications [2]. PZT

($\text{Pb}[\text{Zr}_{(x)}\text{Ti}_{(1-x)}]\text{O}_3$) is a ferroelectric material which has excellent piezoelectrical and pyroelectrical properties. The structure of this piezoelectric ceramic is perovskite [3]. Piezoelectric materials are important for MEMS and NEMS because of their possibility to convert one form of energy to another.

When piezoelectric material is placed under mechanical stress, a shifting of the positive and negative charge centers in the material takes place, which then results in an external electrical field. When reversed, an outer electrical field either stretches or compresses the piezoelectric material [1].

Piezoelectric actuators convert electrical energy to mechanical energy. This is why they are referred to as "motors" (often linear motors). Piezoelectric sensors convert mechanical energy into electrical energy. This is why they are referred to as "generators". In most cases, the same element can be used to perform either task [3]. Piezoelectric sensors or piezoelectric generators are very interesting for engineers for that they can be used for energy harvesting devices for MEMS. They can be single-layer, bilayer or multilayer generators depending on the number of piezoelectric layers. Single-layer structure which is longitudinal (d_{33}) generator is shown in Fig. 1. This means that mechanical stress is applied in direction parallel to polarization [4]. The case for bilayer structure is the same but there are two piezoelectric layers.

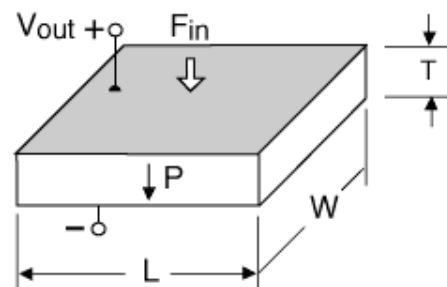

Fig. 1. Single-layer piezoelectric structure [4]

Traditionally, the PZT and ZnO are used as bulk materials with thickness higher than 100-200 μm , which are difficult to be integrated into microdevices. In this paper these materials are used like thin films with thickness around x.100 nm. A suitable approach for piezoelectric performance improvement could be combination of different piezoelectric materials, but this hypothesis should be studied. That's why in this research, the piezoelectric effect was investigated for two types of samples, consisting of piezoelectric thin films PZT and ZnO, RF sputtered. Two single-layer structures and one bilayer structure are produced. The piezoelectric reaction and

¹Yordanka Vucheva, Georgi Kolev, Mariya Aleksandrova and Krassimir Denishev are with the Department of Microelectronics, Faculty of Electronic Engineering and Technologies at Technical University of Sofia, 8 Kl. Ohridski Blvd, Sofia 1000, Bulgaria, E-mail: ydv@tu-sofia.bg.

generation of the electrical energy of these structures are investigated by experimental setup for dynamic mode measurement.

II. EXPERIMENTAL WORK

A. Producing of the samples

The experimental work begins with the manufacturing of the samples. Three samples were made with two piezoelectric materials – PZT and ZnO. Two of the samples were single-layer structures with one piezoelectric layer PZT or ZnO, and the third sample was bilayer structure, consisting of two piezoelectric layers in combination PZT and ZnO. All of the samples were obtained on polyethylene terephthalate (PET) substrates. This foil type material was chosen, due to its high flexibility and ability for easy deformation, which additionally stimulates generation of piezoelectric voltage. On the PET pieces aluminum (Al) 200 nm films were deposited by thermal evaporation in vacuum chamber A400-VL Leybold Heraeus at vacuum level 10^{-5} Torr for bottom and top electrodes. The piezoelectric layers were deposited by RF sputtering at total partial pressure of $2 \cdot 10^{-2}$ Torr. The sputtering conditions were as follows: $U_{pls}=0,6kV$, $I_{pls}=150mA$, $P_{pls}=90W$ (specific plasma power $11,8W/cm^2$). The time of the deposition was 50 min for PZT and 20 min for ZnO. The thicknesses of the PZT and ZnO layers were measured respectively 200nm and 60nm by AlfaStep Tencor 100. The deposition conditions were changed, because of the fact that, due to the processing temperature the substrates started to be softer. Therefore the thicknesses of the piezoelectric layers are different than expected. The size of the top electrode was $2 \times 1,5$ mm, defined by shadow mask.

The both single-layer structures are with PZT and ZnO, separately and the other bilayer structure is consisting of the PZT and ZnO one over another. Cross-section view of the single-layer and two-layer structures is shown in Fig. 2.

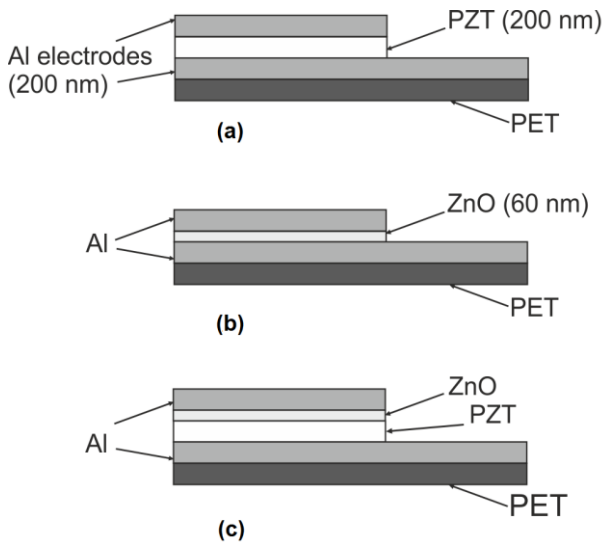

Fig. 2. Cross-section view of single-layer (a), (b) and bilayer structures (c)

B. Measuring the piezoelectric reaction in dynamic mode

The piezoelectric reaction of the samples was measured by lab made experimental setup for dynamic mode, which is shown in Fig. 3.

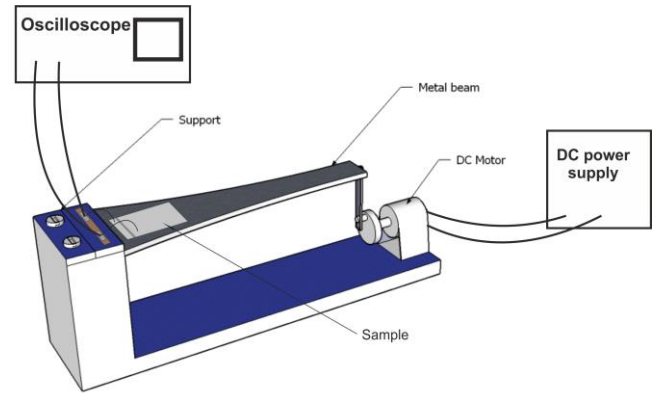

Fig. 3. Experimental setup for dynamic mode measurement of the piezoelectric reaction

A picture of the experimental setup is shown in Fig. 4.

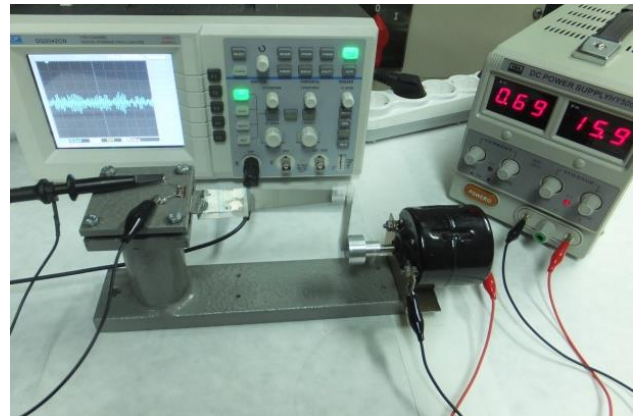

Fig. 4. The experimental setup

To measure this reaction, every sample was fixed to the beam by single component adhesive Z70 and then was bonded to the measurement leads. The generated piezoelectric voltage was measured at different frequencies vibrations of the metal beam, which are induced and defined by the DC motor. The maximum strength of the experimental stand is 1096 gr or 10,75 N. The time sweeps of the generated oscillations were observed by digital oscilloscope DQ2042CN.

The measurements for all samples were done at equal conditions for values of the voltage from the DC power supply in the range 14-20 V and vibrations of the metal beam in the range 23-55 Hz.

III. RESULTS AND DISCUSSION

The signals, for the generated piezoelectric voltage, were measured for all piezoelectric structures at the following values of the DC power supply 14 V, 16 V, 18 V and 20 V. At these values of the voltage, applied to the motor, the frequencies of the metal beam vibrations are 23 Hz, 33 Hz, 45Hz, 55Hz, respectively. Below the signals from the structures and the discussions about them are shown.

A. Single-layer structure with PZT

Single-layer structure with piezoelectric layer of PZT was subjected to vibrations with different frequencies, which induced measurable piezoelectric charge inside the layer. The generated voltage from the 200nm thick piezoelectric layer is in the range 40-60mV, as the values of 40mV are measured at 23 Hz and 33 Hz (Fig. 5 (a)) and the values of 60mV at 45 Hz and 55 Hz (Fig.5 (b)). Fig. 5. presents two signals of the mentioned values of the generated piezoelectric voltage. It should be mentioned that the value 60mV of the voltage exists as peaks in the output signal and it is not permanent. This is actually expected, because the elastic beam move frequently and it passes through certain position often so the voltage peaks with similar frequency can be monitored on the oscilloscope screen.

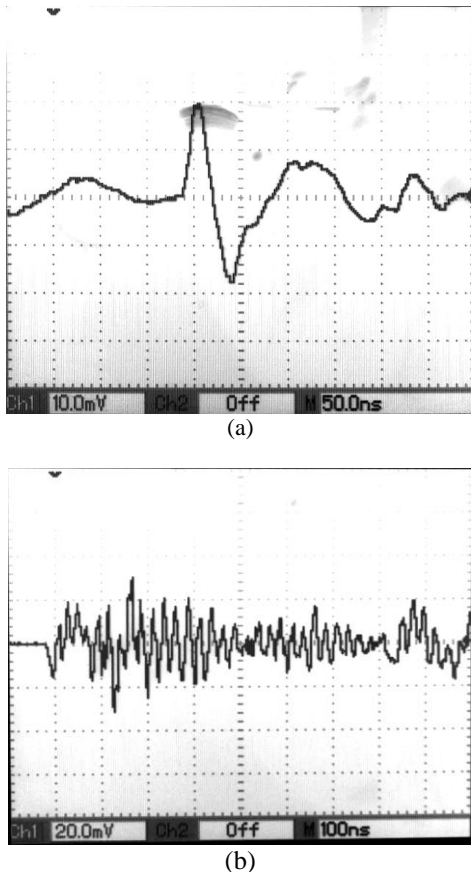

Fig. 5. Output voltage signals of the generated piezoelectric voltage from single-layer structure with PZT

With the increasing of the frequency, the peaks in the output signal of voltage are higher, but sparsely. In the range 23-33 Hz of the vibrations, the piezoelectric voltage consists of more peaks in the signal, with higher value.

B. Single-layer structure with ZnO

At the same conditions the output signals of the generated voltage were taken from the one-layer piezoelectric structure with ZnO. In this case, the generated voltage, from the 60nm thick piezoelectric layer, is in the range 80-100 mV, and like in the previous case the highest voltage is generated in the range 23-33 Hz. In Fig. 6 two output signals for 80 mV (a) and 100 mV (b) are shown. 80 mV of the generated piezoelectric voltage was measured at 23 Hz, 45 Hz and 55 Hz. The value of 100mV, was measured at 33 Hz.

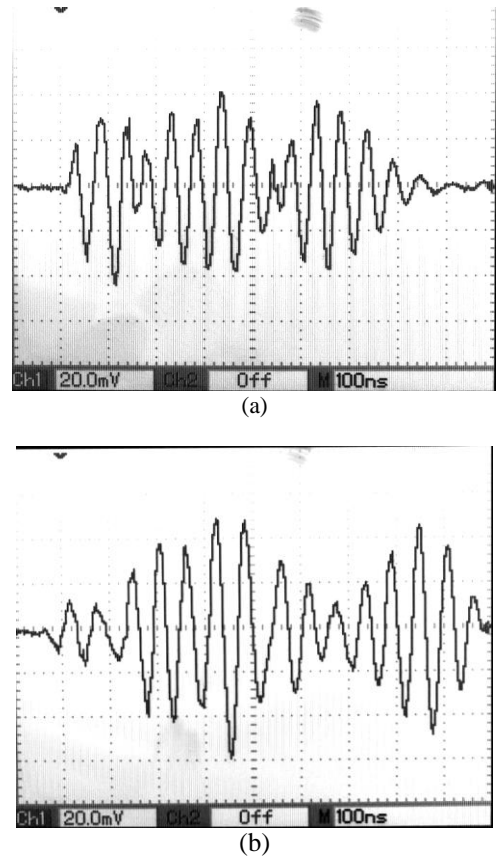

Fig. 6. Output voltage signals of the generated piezoelectric voltage from single-layer structure with ZnO

C. Bilayer structure with PZT and ZnO

For this bilayer structure PZT layer was firstly deposited, and the second one was from ZnO. In this case the generated piezoelectric voltage is almost half of this in the previous one-layer structures. Its value is in the range 30-40 mV for all frequencies and values of 80mV were monitored rarely for 45 Hz and 55 Hz measuring points, due to depolarization or inability of the dipoles of both materials to follow the change of the mechanical load with one and the same rate, so the

slowest one (PZT) cannot produce a charge. This behavior is probably due to the increased inner capacitance of the bilayer structure. Fig. 7. presents some of the captured signals of the generated piezoelectric voltage from the bilayer structure.

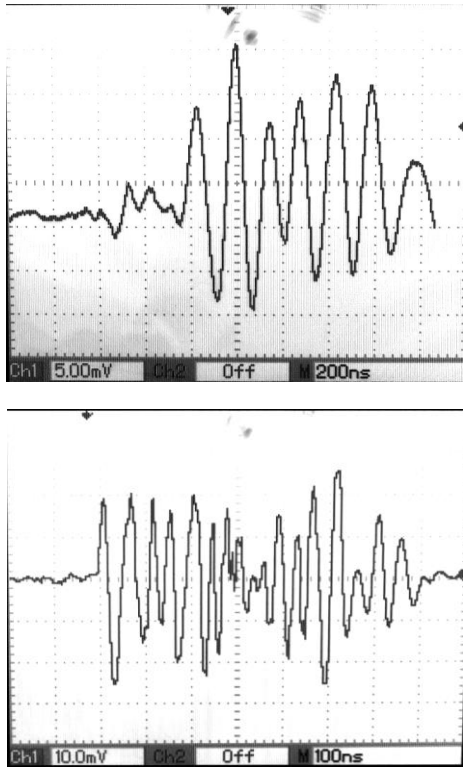

Fig. 7. Output voltage signals of the two-layer structure with PZT and ZnO

From the comparison of the bilayer structure with the single-layered ones, it can be seen that the voltage values, generated by the bilayer structure, are almost half of these from the single-layer structures.

IV. CONCLUSION

After considering the generated piezoelectric voltage signals of the all structures, it could be concluded that, bilayer structure have a lower output voltage, comparing the single-layer piezoelectric structures. The voltage values, generated by the bilayer structure, are almost half of these from the single-layer structures. This can be explained by the electrical charge of the structures. Bilayer structure generates a higher charge than single-layer structures, but the inner capacitance is bigger and, as a result, the generated voltage is lower. That should be studied in the future work.

For the single-layer structures, more interesting is the fact that the 60nm ZnO layer has almost the same voltage values as the voltage, obtained by the 200nm PZT layer. This could be as a consequence of the piezoelectric coefficients of the layers, but the future work should be done for confirmation the reason of that.

Another fact is that the value of the output voltage, at 23 Hz and 33 Hz, for single-layer samples, is lower but for bilayer sample is higher. At high frequencies, is just in opposite, the value of the voltage, for single-layer samples, is higher but for bilayer samples is lower.

ACKNOWLEDGEMENT

The research, described in this paper, was carried out within the framework of the contract № 142pd0064-03/2014.

REFERENCES

- [1] <http://www.nanomotion.com/piezo-ceramic-motor-technology/piezoelectric-effect/>
- [2] Johnson, R. L., "Characterization of piezoelectric ZnO thin films and the fabrication of piezoelectric micro-cantilevers", Iowa State University, 2005.
- [3] Kolev, G.D., "Investigation of piezoelectric effect in thin layers, for application in harvesting devices and MEMS sensors", Annual Journal of ELECTRONICS, ISSN 1314-0078, 2012.
- [4] <http://www.piezo.com/tech2intropiezotrans.html>
- [5] Gretarsson D., "Energy Harvesting using Piezoelectric Generators", Copenhagen, 2007.
- [6] B. Jaffe, W. Cook, H. Jaffe, "Piezoelectric Ceramic", Academic Press, London and New York, 1971.
- [7] T.L. Jordan, Z. Ounaies, "Piezoelectric Ceramics Characterization", ICASE Report No. 2001-28.