

# DEVELOPMENT OF SOUND SOURCE LOCALIZATION MODULE BASED ON MEMS TECHNOLOGY

V. Hristov

Department of Telecommunications,  
Technical University - Sofia, Kliment Ohridski 8, Sofia  
hristov.viktor@gmail.com

## Abstract

*Sound source localization is a wide spread method for finding direction from where the sound waves come from a sound source to a listener. If the listener is a person, the human hearing system do this sound source localization very precise, but in cases when the listener is an automatic system for example a mobile robot, a surveillance system, a videoconference system, etc., this sound source localization is not so easy to do. Usually the realization of an automatic sound source localization system is based on microphone arrays as hardware and on some developed methods and algorithms as software for processing sound signals from each of the microphones in microphone array, leading to angle determination of sound source direction of arrival to the place of microphone array.*

*The goal of this article is to develop an appropriate sound source localization module working as a microphone array based on MEMS technology.*

**Keywords:** *Sound Source Localization Module, MEMs Technology, Development, Signal processing*

## 1. INTRODUCTION

Since the invention of the telephone systems, sound signals become an essential part of acoustic and speech processing. Traditionally, sound signals are recorded with the use of only one microphone, but this was with some limitations. To preserve the sound fidelity, spatial realism and increase the processing flexibility with multiple sources, microphone arrays were invented [1].

A microphone array consist of a number of acoustic sensors positioned on the proper distance between each other in a way that spatial information can be captured [2]. As a result, the array outputs contain signal of interest, noise, interference and also propagation information that is represented by the acoustic impulse response from the radiating sources to the microphones.

The most popular methods used in microphone arrays are for sound source localization. They can be defined in three main groups: dependent from time of arrival, fixed beamforming and adaptive (hybrid) beamforming using correlation functions [3].

Beamforming is spatial filtering based on microphone characteristics and microphone array configuration. It can be classified in two groups: fixed

(classical) and adaptive (hybrid) depending of the input data [3].

There are two scenarios dependent of the distance from source to the microphone: far-field and near-field. Depending of the place, were experiment was done it could be open space, without any reflections and in closed space, also called multipath propagation, because each reflection from the wall or object can be treated as a separate source [4].

Micro-electromechanical systems (MEMS) is a new technology allow to realize the sound localization module as micro miniature device and as a programmable system changing microphone array configuration. This process technology used to create a tiny integrated devices or systems that combine mechanical and electrical components [5].

In the beginning of this article are mentioned main existing sound localization methods are their possibilities to implement in microphone arrays devices. The MEMS technology is also briefly presented to define it ability for development of a microphone array using MEMS microphones [6]. The steps of sound source localization module development applying MEMS microphones are described carefully in the next parts of this article and after that are presented some results of developments: sound source localization module functional schema, simulation of some possible configurations (number

of MEMS microphones, space structure of microphones placement in microphone array, etc.) of microphone arrays in developed sound source localization module and some important characteristics of the developed sound source localization module.

The target of this experiment is to develop an appropriate sound source localization module working as a microphone array based on MEMS technology.

**2. BLOCK DIAGRAM OF THE DEVELOPED SOUND SOURCE LOCALIZATION MODULE**

On Fig. 1 is shown block diagram of the constructed and investigated device. It consists n-microphones from MEMS type from which will be received audio signals.

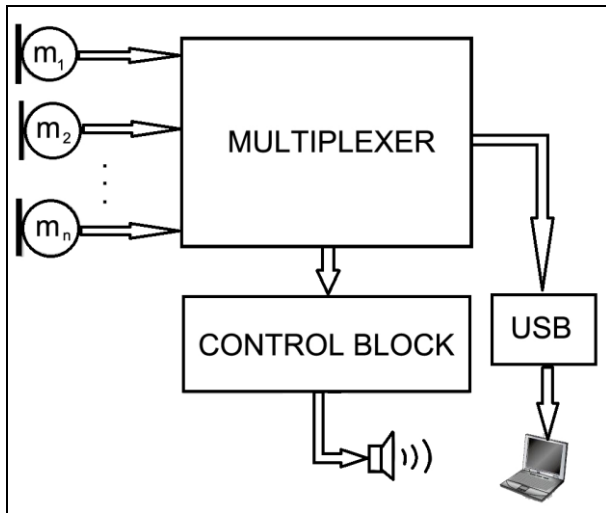

Fig.1. Block diagram of SSL module

Then they were processed in multiplexor block where the signals are converted to a standard data stream. After that received output can be amplified and heard using a control block and speaker. The other output option is to be visualized following the USB interface and proper computer software.

**3. DEVELOPMENT OF THE PRINCIPLE SCHEME OF THE SOUND SOURCE LOCALIZATION MODULE**

For realization the sound source localization module is used equipment from ST Microelectronics producer. On Fig. 2 is shown all used components that is need for realization – MEMS microphones, multiplexor, control block, software and computer or laptop.

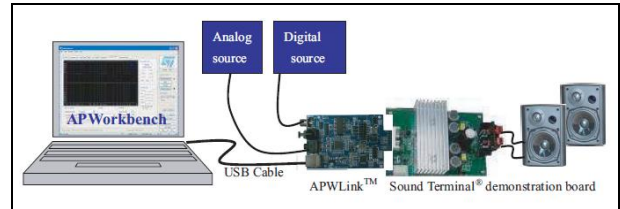

Fig. 2. Block diagram

On Fig. 3 is shown multiplexer block diagram. Analog signal which was received from MEMS Microphone 1-6, will be digitalized in PDM interface. After that it is possible mixing and filter applying and all calculations will be done from scalable microphone processor. Finally the signal can be recorded or played back depending of the used outcome.

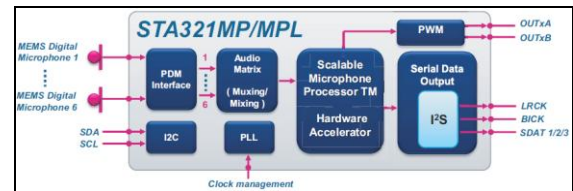

Fig. 3. Multiplexer block diagram

**3.1. Used components**

For project implementation are used MEMS microphones MP34DB01, board components STEVAL-MKI126V2, MKI129V2 and CCA035V1 and of STMicroelectronics.

**3.1.1. MEMS microphone choice**

The MP34DB01 (Fig. 4) is an ultra-compact, low-power, omnidirectional, digital MEMS microphone built with a capacitive sensing element.

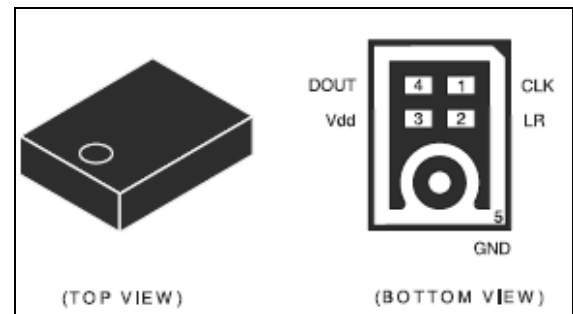

Fig. 4. MP34DB01 microphone

The IC interface is with stereo operation capability is manufactured using a CMOS process that allows to design a dedicated circuit able to provide a digital signal externally in PDM format. The MP34DB01

has an acoustic overload point of 120 dB SPL with a best on the market 62.6 dB [8].

### 3.1.2. Multiplexor development

The STEVAL-MKI126V2 system evaluation board (Fig. 5) can connect up to six microphones using the sockets provided or through a dedicated six microphone array.



Fig. 5. STEVAL-MKI126V2

The main purpose of the STEVAL-MKI126V2 is to convert the PDM signals provided by the microphones into the more common I2S and PWM signals. The I2S signal is routed both on general and interface connectors, while the suitably-filtered PWM signals provide an analog interface.

Mounted on the STEVAL-MKI126V2 are two MP34DB01 microphones and an STA321MPL processor [9].

### 3.1.3. Control block

The control block is CCA035V1 demonstration board (Fig. 6) implements an APWLink designed as a USB interface board to control ST Sound Terminal® demonstration boards [10].

In addition, in order to provide controlling signals to external Sound Terminal® demonstration boards, analog/digital audio inputs are also provided within APWLink.



Fig. 6. Control block CCA035V1

### 3.1.4. Microphone adapters

Microphone adapters are small circular PCBs with a single soldered MEMS microphone. Used board STEVAL-MKI129V2 (Fig. 7) is with mounted digital microphone - MP34DB01 [11].



Fig. 7. Microphone adapter MKI129V2

## 3.2. Used program products

For visualization of the sound signals is used APWorkbench software suite (Fig. 8).

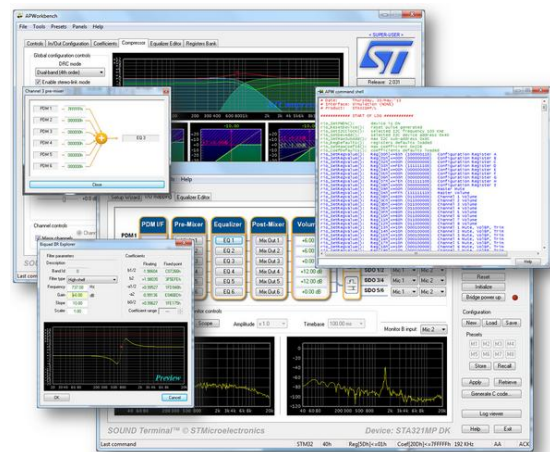

Fig. 8. APWorkbench software

It provides a comprehensive environment for the customer to explore, evaluate and configure devices within ST's product portfolio for audio applications, including stereo and multi-channel amplifiers, DSP and digital MEMS microphones. The tool rep-

resents a unique solution enabling the user to conveniently evaluate, configure and tune advanced audio IPs embedded in ST's Sound Terminal® products.

Custom controls and a user-friendly graphical interface expose the complexity of today's audio devices in a simple and intuitive manner, guiding the novice through the basic configuration steps and providing acoustic expertise to tune the devices for optimal performance.

### 4. SOFTWARE SYSTEM FOR EXPERIMENT WITH MEMS MICROPHONE ARRAYS

Starting software is used the option STSmartVoice Demo Kit (Fig. 9). Selection of the USB port APWLink interface (1) starts communication between software and module. This will be used for realtime manipulation of the audio input. There is another option - "USB digital voice recorder" which provides ability to save audio in digital format. This will be used for storing and audio probes and after that investigation of the sound source localization using different techniques.



Fig. 9. Module choice

Before applying the configuration (Fig. 9) it can be selected the number of used microphones (2 – 6). There are two onboard MEMS microphones and there is an option up to four – using the digital microphone interface. In further investigation different type of microphone arrays can be constructed and applied.

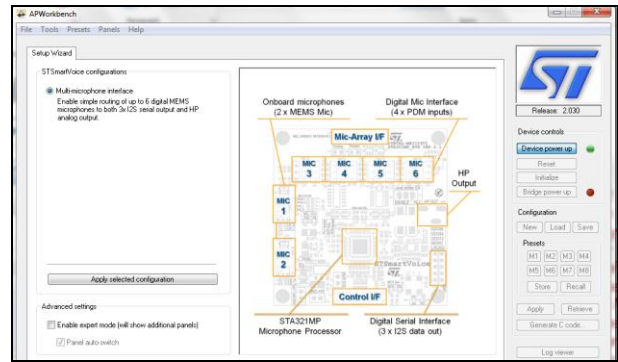

Fig. 10. Microphone selection

On Fig. 11 is shown the application of filter. There is a choice between LoPass, HiPass, LoShelf, HiShelf Notch, AllPass filters. Optional can be fine-tuned all coefficients.

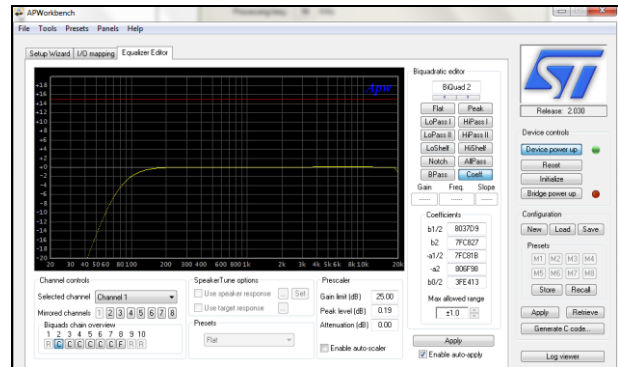

Fig. 11. Apply filters

Optional can be imported filter (Fig. 12) from Math Lab using the Fdatool.

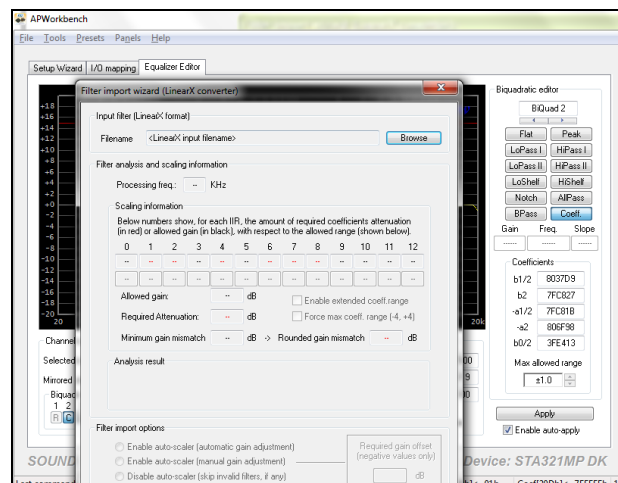

Fig. 12. Filter import

Beamforming of the microphone arrays allows to use summation of the signal (Fig. 13). The signal's amplitude can be configured before application of the filter.



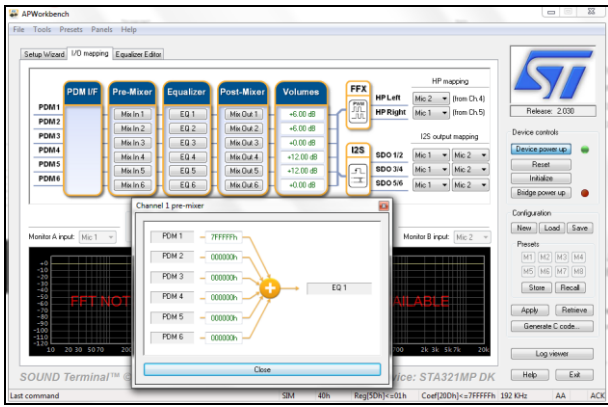

Fig. 13. Beamforming of the microphone array

This is analog of the block diagram shown on Fig. 14 for filter-and-sum beamforming technique. Each filter coefficient  $\omega_n$  can be set separately in hexadecimal values.

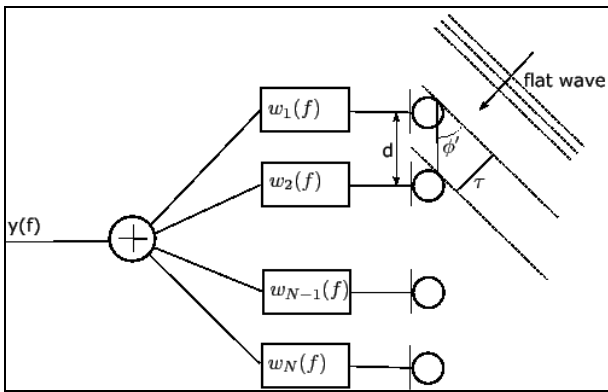

Fig. 14. Filter-and-sum algorithm blocks diagram

The input signal (considered to be coming from a distant source and flat) arrives to each microphone from an angle  $\phi'$  at a different time instant. The signals from the different microphones are passed through a filter  $\omega_n$ , independent for each microphone (1 through N), which accounts for an amplitude and time delay.

$$y(f) = \sum_{n=1}^N w_n(f)x_n(f) \quad (1)$$

The output signal  $y(f)$  is the sum of all signals from MEMS microphones  $M_1, \dots, M_N$ .

This type beamforming technique was selected for the implementation of the meetings systems because it agrees with all desire characteristics. Furthermore, its simplicity allows for a fast implementation, normally under real-time, that allows it to eventually be used in a real-time system.

## 5. CONCLUSION

This article was presented developed hardware and software system for Sound Source Localization using beamforming technique. It was described MEMS technology which was used to construct the module.

There are used line microphone array modules and in future investigation will continue with assembling and constructing other different types. There are described all interfaces, which can be used for the connection with computer. It was presented the software that can manage and exanimate the different configurations of modules attached.

In future using the same microphones with different position to investigate their ability to Sound Source Localization using beamforming technology.

## Acknowledgment

This paper was supported by Technical University – Sofia inner program to support PhD research projects under Contract 142 PD 0018-07: “Development of methods and tools to locate audio sources in information and communication networks”.

## References

- [1] J. Benesty, and J. Chen, *Study and Design of Different Microphone Arrays*, 2013.
- [2] Muller, R.S., Howe, R.T., Senturia, S.D., Smith, R.L., and White, R.M, *Microsensors*, IEEE Press, New York, 1991.
- [3] Yong Rui and Dinei Florencio, “New direct approaches to robust sound source localization”, January, 2004.
- [4] Iain McCowan, *Microphone Array*, April 2001.
- [5] Banesty, Jacob, Chen, Jingdong, Huang, Yiteng, *Microphone Array Signal Processing*, 2008.
- [6] Trimmer, W.S., *Micromechanics and MEMS: Classic and Seminal Paper to 1990*, New York, NY, 1997
- [7] *An Introduction to MEMS, Prime Faraday Technology Watch*, 2002
- [8] [http://www.st.com,MP34DB01 datasheet](http://www.st.com,MP34DB01)
- [9] [http://www.st.com,Steval-MK1126v2 datasheet](http://www.st.com,Steval-MK1126v2)
- [10] [http://www.st.com,CCA035V1 datasheet](http://www.st.com,CCA035V1)
- [11] [http://www.st.com,Steval-MK1129V2 datasheet](http://www.st.com,Steval-MK1129V2)