

КОМПЮТЪРНО УПРАВЛЯВАН ИЗМЕРВАТЕЛЕН УСИЛВАТЕЛ

" , "

" " "ó" . " '39; 9." . " 0õ 0" ö"

P q0 . " 03'G/o ckn ["dai cpqx B w/uqlhc0li 0"](#)

Abstract 0' k" y ku" r cr gt "ku" r t g u g p v g f " c " v g e j p l e c n i u q n w k q p . " f g u k i p " c p f " y g " k o r m g o g p v k q p " q h " c " e q u v ' g h g e v k x g " f k i k c m f " e q p v t q m g f " r t q i t c o o c d n g / i c k p " k p u t w o g p v k q p " c o r n k l g t 0 V j g " c o r n k l g t " k u " e q o r q u g f " q h " y q " e c u e c f g f " u c i g u . " d c u g f " q p " R I C 4 2 4 1 4 2 5 0 " K ' e c p " d g " e q p v t q m g f " y k j " F C S " P K W U D 8 2 2 : 1 ; " c p f " N c d X K G Y . " q t " y k j " o l e t q e q p v t q m g t 0 ""

Keywords < k p u t w o g p v k q p " c o r n k l g t . " N c d X K G Y . " r t q i t c o o c d n g " i c k p " c o r n k l g t 0 "

УВОД

" " " " " " * k p u t w o g p v k q p " C o r n k l g t u + "

" " " " " " " " " " " " " " " "

" " 0' " " " " " " " " " " " " " "

" " " " C w " " " " " " 3 " 3 2 2 2 2] 3 . 3 3 _ 0 " "

" " " " " " " " " " " " " " " " " E O T T 0' "

" " " " " " 0' " " " <

- " " " C w 0 " " " " " " " " " "
- " " " * + " " " " " " 0' " " " " " "
- " " " " " " " " " " * I c k p " G t t q t + 0 " "
- / " " " " " " " " " " " " " 0' " " " " "
- "
- " " " 0' " " " " " " " " " " " " " "
- " " " ТЮ " " " " " " " " " " " " " "
- " " " " " " " " " " á . " " " " " " " " " "
- " " " " " " " " " " " " I á 0' " " " " " "
- " " " D c p f y k f y j "/ " D Y + 0' " " " " " " " " " "
- " " " " " " " " " " " " " " " " " " 0' " " " " "
- " " " " " " " " " " " " " " " " " " " C w " " " " " "
- " 0' " " " " " "
- " " " " " " " " " " " " " " " " " " " * E q o o q p " O q f g " "

T g l g e v k q p " T c v k q + 0'

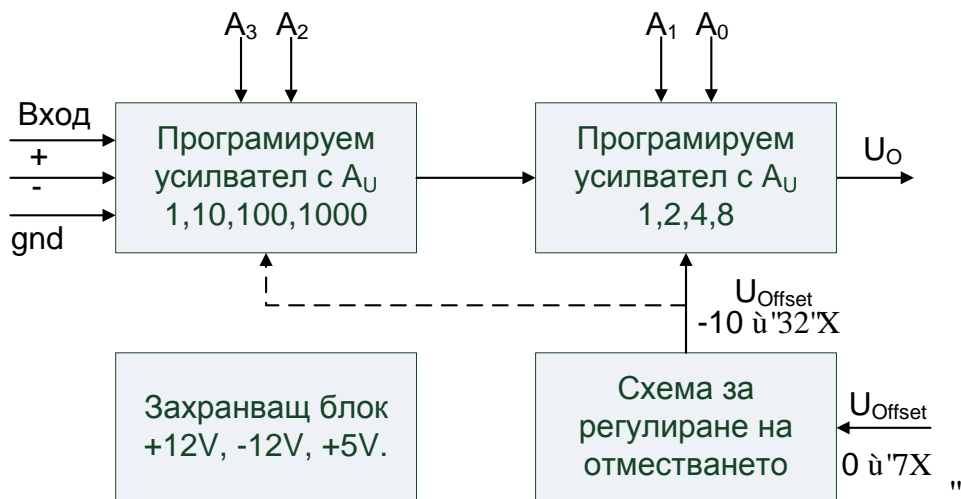

Фигура 10' " " " 0'

ПРОЕКТИРАНЕ НА ПРИНЦИПНАТА ЕЛЕКТРИЧЕСКА СХЕМА И РЕАЛИЗАЦИЯ

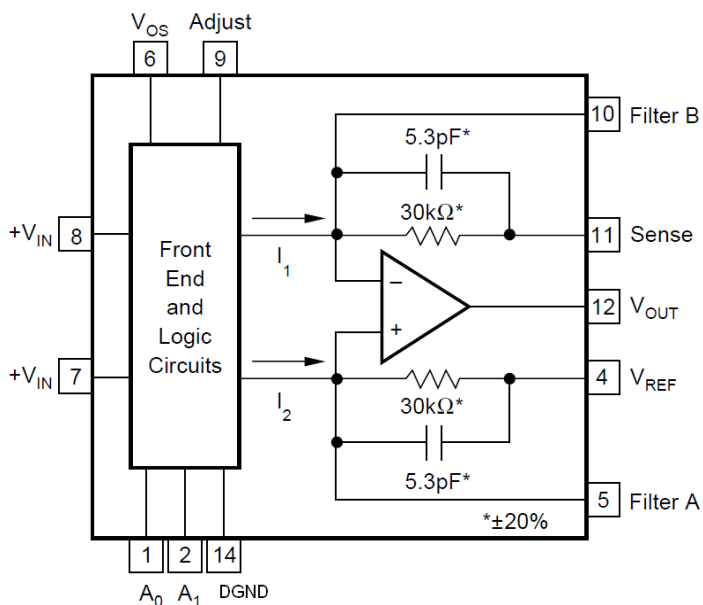

Фигура 20' " " " RI C424 I425"

VVNIEO QU'
04"

" " " " RI C424 I4250"

" HGV"

"3'UH0"

"Ugpug" "Xtgh"

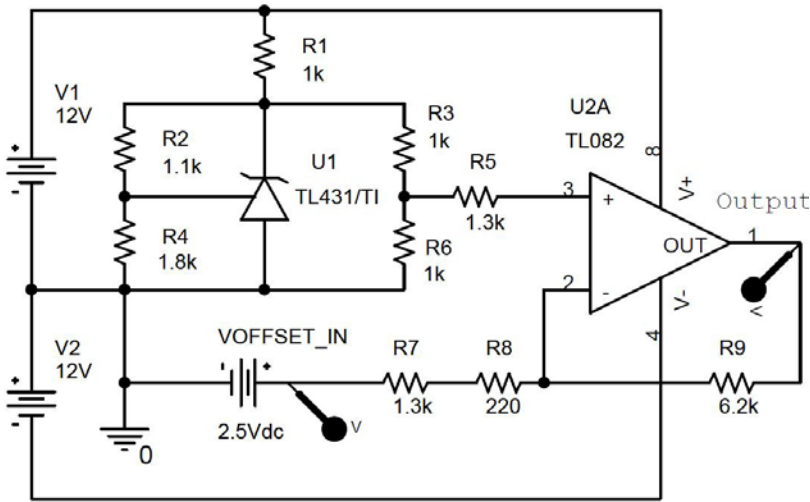

Фигура 3.

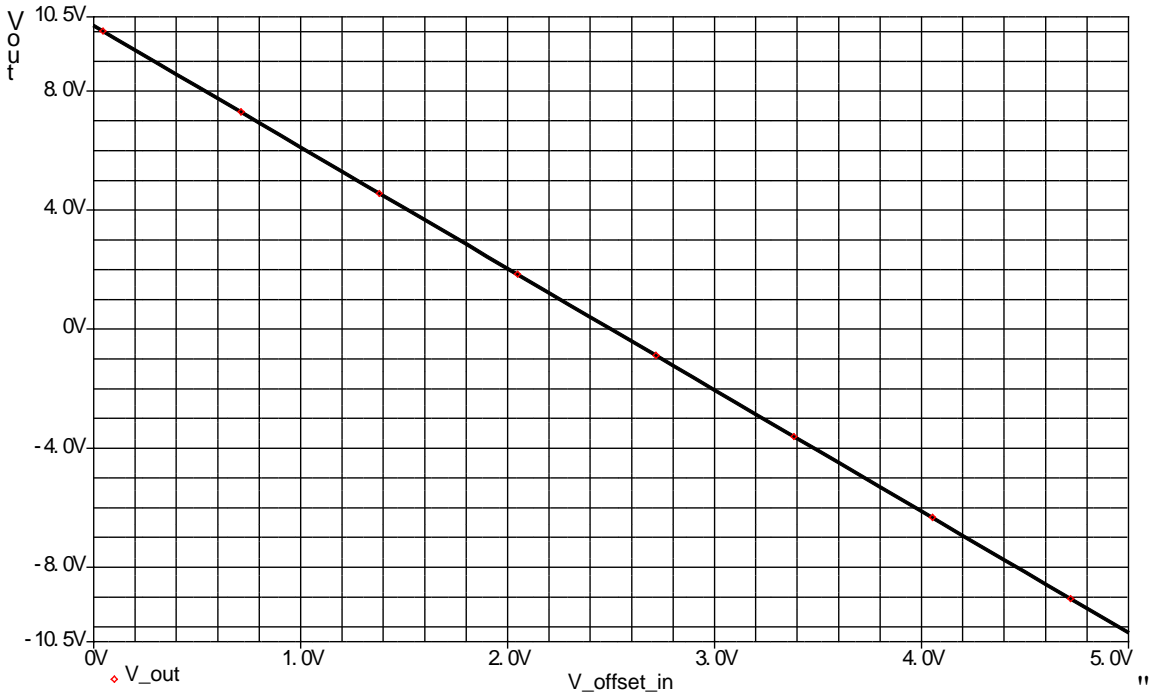

Фигура 40

